

CHANGE™

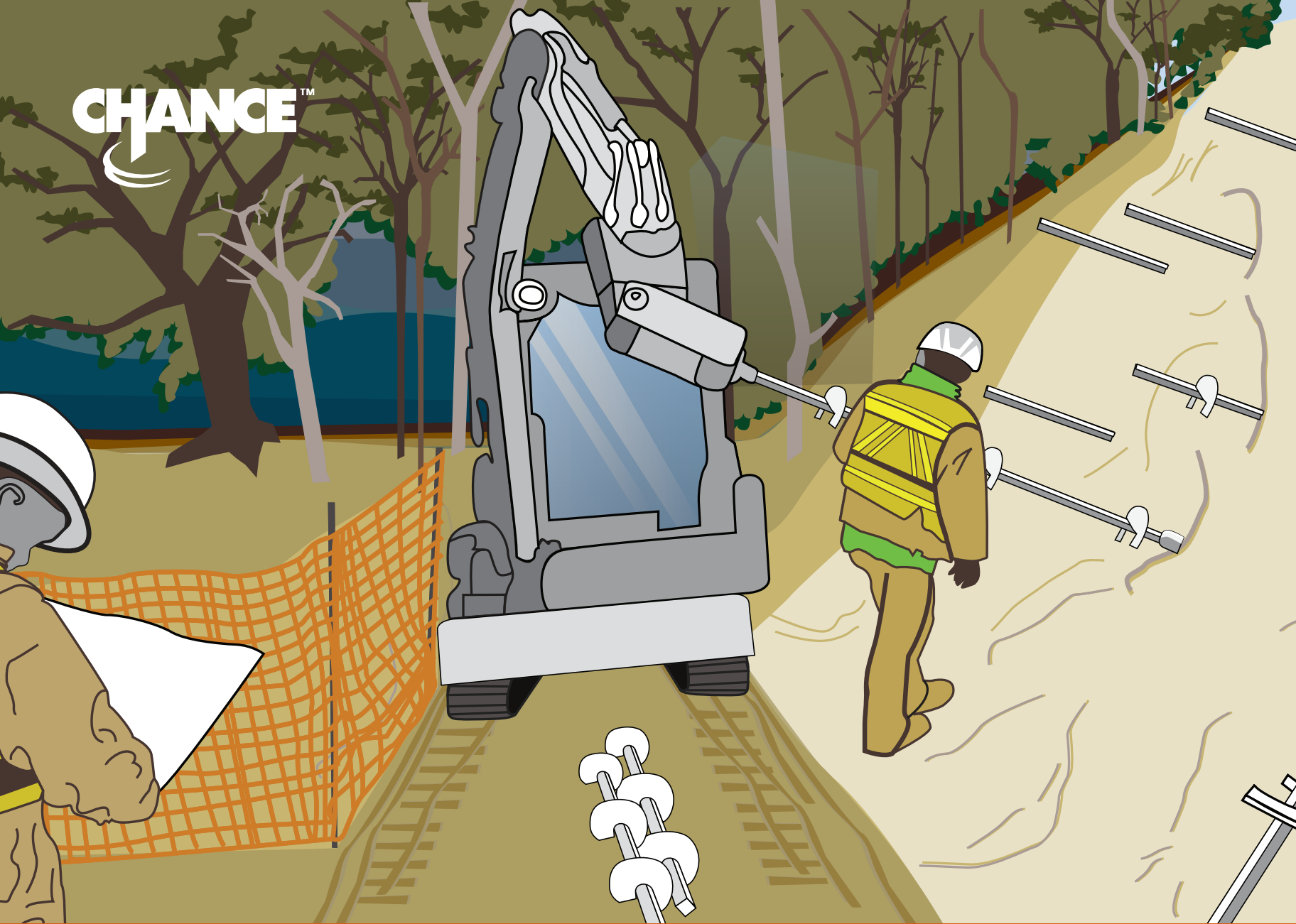

Soil Screw Design Manual Edition 2



TABLE of CONTENTS

INTRODUCTION and APPLICATIONS Section 1

PURPOSE AND SCOPE.....	1-3
SOIL NAIL TECHNOLOGY	1-3
History of Soil Nailing	1-3
Definition.....	1-4
Screw Anchor Soil Nails.....	1-5
Grouted Soil Nails	1-8
Comparison with Tieback Walls	1-8
Comparison with MSE Walls.....	1-9
SOIL NAIL APPLICATIONS	1-11
ADVANTAGES OF SOIL NAIL WALLS	1-14
LIMITATIONS.....	1-14

SOIL NAILING WITH THE SOIL SCREW® RETENTION WALL SYSTEM Section 2

DESIGNING WITH THE SOIL SCREW® RETENTION WALL SYSTEM.....	2-3
Facing Deformation	2-3
Pullout Resistance.....	2-3
Tensile Strength of a Screw Anchor.....	2-3
DATA REQUIRED FOR SOIL NAIL DESIGN	2-3
Soil Parameters	2-4
Surcharges and Loading Conditions	2-5
Drainage and Groundwater Conditions.....	2-5
FACING CONSIDERATIONS.....	2-6
Temporary Facings	2-6
Permanent Facings - Figure 2.3.4	2-8

**DESIGN GUIDELINES FOR SOIL NAILED WALLS
UTILIZING THE SOIL SCREW® RETENTION WALL SYSTEM**
Section 3

SITE INVESTIGATION.....	3-4
Regional Geology.....	3-4
Field Reconnaissance.....	3-4
Subsurface Exploration.....	3-4
Laboratory Testing.....	3-5
PRELIMINARY FEASIBILITY ASSESSMENT.....	3-5
Ground Conditions Best Suited for Soil Nailing with the SOIL SCREW® Retention Wall System.....	3-5
Ground Conditions Considered Not Favorable for Soil Nailing Using the SOIL SCREW® Retention Wall System	3-6
Design Charts.....	3-6
OVERVIEW OF DESIGN METHODOLOGY.....	3-6
EXTERNAL STABILITY	3-8
Earth Pressures for External Stability.....	3-8
Sliding Stability.....	3-11
Bearing Capacity	3-12
INTERNAL STABILITY.....	3-13
Allowable Nail Strength.....	3-13
Pullout Capacity of Nail	3-15
Pullout of Screw Anchors in Sands and Silts	3-15
Facing Design	3-17
Flexural Strength of the Facing.....	3-18
Punching Shear Strength of the Facing.....	3-20
Cantilever Design Check.....	3-22
Nail Strength Envelope	3-23
Internal Stability Limit Equilibrium Analysis.....	3-23

GLOBAL STABILITY	3-24
SUMMARIZED DESIGN STEPS.....	3-24
SPECIAL DESIGN CONSIDERATIONS.....	3-25
Tiered Walls	3-25
Surcharge Loads - Figure 3.8.1.....	3-25

**CONSTRUCTION - MATERIALS,
INSTALLATION AND MONITORING**
Section 4

MATERIALS.....	4-3
Screw Anchors	4-3
Wall Connectors	4-4
Shotcrete.....	4-5
Drainage Materials.....	4-6
ALTERNATE FACING MATERIALS.....	4-6
INSTALLATION EQUIPMENT	4-6
INSTALLATION, MONITORING AND TESTING	4-7
Installation	4-7
Monitoring and Testing	4-10

SPECIFICATIONS
Section 5

PRODUCT SPECIFICATIONS.....	5-2
PERFORMANCE SPECIFICATION.....	5-2

REFERENCES
Section 6

DESIGN CHARTS AND DESIGN EXAMPLES

Appendix A

APPENDIX A1 - DESIGN CHARTS	A-3
FIGURE A-1 SOIL SCREW® RETENTION WALL SYSTEM PRELIMINARY DESIGN CHART	A-3
FIGURE A-2 SOIL SCREW® RETENTION WALL SYSTEM PRELIMINARY DESIGN CHART	A-3
FIGURE A-3 SOIL SCREW® RETENTION WALL SYSTEM PRELIMINARY DESIGN CHART	A-4
APPENDIX A2 - DESIGN EXAMPLES.....	A-5
ATTACHMENT EX1 - INTERNAL STABILITY USING GOLDNAIL.....	A-13
ATTACHMENT EX2 - GLOBAL STABILITY ANALYSIS USING STABL.....	A-21

EXAMPLE SPECIFICATIONS (PERMANENT AND TEMPORARY)

Appendix B

APPENDIX B1 (OWNER-DESIGN) GUIDE SPECIFICATION FOR SOIL SCREW® RETENTION WALL SYSTEM	B-3
APPENDIX B2 (DESIGN-BUILD SOLICITATION) GUIDE SPECIFICATION FOR SOIL SCREW® RETENTION WALL SYSTEM.....	B-13

INTRODUCTION SECTION 1

CONTENTS

PURPOSE AND SCOPE.....	1-3
SOIL NAIL TECHNOLOGY	1-3
History of Soil Nailing.....	1-3
Definition.....	1-4
Screw Anchor Soil Nails.....	1-5
Grouted Soil Nails.....	1-8
Comparison with Tieback Walls	1-8
Comparison with MSE Walls.....	1-9
SOIL NAIL APPLICATIONS	1-11
ADVANTAGES OF SOIL NAIL WALLS	1-14
LIMITATIONS	1-14

DISCLAIMER

The information in this manual is provided as a guide to assist you with your design and in writing your own specifications.

Installation conditions, including soil and structure conditions, vary widely from location to location and from point to point on a site.

Independent engineering analysis and consulting state and local building codes and authorities should be conducted prior to any installation to ascertain and verify compliance to relevant rules, regulations and requirements.

Hubbell Power Systems, Inc., shall not be responsible for, or liable to you and/or your customers for the adoption, revision, implementation, use or misuse of this information. Hubbell, Inc., takes great pride and has every confidence in its network of installing contractors and dealers.

Hubbell Power Systems, Inc., does NOT warrant the work of its dealers/installing contractors in the installation of CHANCE® Civil Construction foundation support products.

PURPOSE AND SCOPE

The purpose of this manual is to introduce the concept of soil nailing to civil engineers and to provide guidance on how to design soil nail walls using the CHANCE® SOIL SCREW® Retention Wall System. The manual includes:

- Chapter 1 - An Overview of Typical Soil Nail Technology and Applications
- Chapter 2 - An Overview of Soil Nailing with the SOIL SCREW® Retention Wall System
- Chapter 3 - Design Guidelines for Soil Nail Walls using the SOIL SCREW® Retention Wall System
- Chapter 4 - Construction and Installation Guidelines
- Chapter 5 - Specifications for SOIL SCREW® Retention Wall Systems
- Appendix A - Design Charts and Design Example
- Appendix B - Example Specifications

This manual was developed using the design methodology presented in the Federal Highway Administration's "Manual for Design and Construction Monitoring of Soil Nail Walls," Report No. FHWA-SA-96-069, dated November 1996. This manual is intended to be a supplement to the FHWA manual to help users take advantage of the benefits of the SOIL SCREW® Retention Wall System. The final design of any structure requires knowledge specific to the soil properties and structural conditions for a particular site. The design of any soil nail wall is the full and complete responsibility of the designer. Hubbell Power Systems, Inc. and its agents assume no responsibility for the design, construction or performance of soil nail structures, even if the design and construction of the walls were performed using CHANCE® Screw Anchors.

SOIL NAIL TECHNOLOGY

History of Soil Nailing

Retaining walls using anchored bars date back to the 1960's and earlier. Soil nailing technology can be traced back to the use of the New Austrian Tunneling Method (NATM), in which grouted rock bolts and shotcrete were used for supporting tunnels. This technology was reportedly first applied for the permanent support of retaining walls in a cut in soft rock in France in 1961. The use of grouted "soil nails" and driven soil nails, which consist of solid steel bars and steel angle iron, continued to grow in the 1970's, in France and Germany. The first wall built in France using current soil nail techniques was reported to have been built by Soletanche, in Versailles in 1972, using a high density of grouted soil nails in sand. The wall was on a 21-degree batter, was 60 feet tall, had a reinforced concrete facing and supported an excavation for a railroad track.

In North America, soil nails were first introduced for temporary excavation support in Vancouver, B.C., in the late 1960's and early 1970's. The first documented project in the U.S. was in Portland, Oregon for excavation support of a hospital foundation. The maximum excavation depth was 45 feet. The soils consisted of medium dense to dense silty fine sands. The work was reported to have been completed in 50 to 70 percent of the time required for conventional tieback construction and at a 15 percent cost saving.

Two major research programs to study soil nailing were undertaken in the late 1970's in Germany (University of Karlsruhe and Bauer Construction) and in the 1980's in France (Clouterre Program). The French program consisted of a \$5 million study, jointly funded by the French government and private industry, with the objective of developing a design methodology for soil nail walls. Considering the results of full-scale testing and monitoring of 6 full-scale structures, the Recommendations of Clouterre, published in 1991, represent the basis for soil nail standards in France.

In 1996 the U.S. Federal Highway Administration published its Manual for Design and Construction of Soil Nail Walls. This manual synthesizes the work in Germany, France and current U.S. practice, to form a guideline for soil nail design for highway works.

Today in the United States, the major use of soil nail walls is for temporary and permanent support of building excavations. Walls up to 75 feet tall have been successfully constructed. This application for soil nailing continues to grow due to the economic benefits it has over conventional tieback construction. Soil nailing has been used for highway applications dating back to the 1980's. Soil nail walls up to 40 feet tall have been used on Federal highway projects. With the development of the FHWA guidelines and promotion of this technique for highway works, the use of soil nailing will continue to grow.

The purpose of this manual is to further promote the use of soil nails in the United States, specifically utilizing screw anchors. Screw anchors represent an advancement over grouted soil nail technology. The SOIL SCREW® Retention Wall System was developed from screw anchor technology used for tieback walls and foundation anchors. This technology has been used successfully for over 40 years.

Definition

A soil nail wall is a gravity composite soil structure in which an excavated slope or vertical cut is internally reinforced through placement of closely spaced linear reinforcing elements. Reinforcing elements are installed by placing them into the existing soil slope or new excavation. Construction is performed in vertical steps, with construction starting at the top of the excavation and proceeding down (Figure 1.2.1). Once an excavated level is reinforced with soil nails, a permanent or temporary facing is applied to retain the soil. The resulting soil structure has soil nails placed to a depth and of a sufficient density to ensure it can resist the forces imposed by the soil and surcharge loads. The failure modes that are analyzed to insure stability for a soil nail wall include sliding, bearing, and global stability failure modes (Figure 1.2.2 and 1.2.3).

There are two different types of soil nails available, screw anchor soil nails and grouted soil nails. While this manual is written for the design of screw anchor soil nail systems, both types are described below.

<p>Some of the Advantages of screw anchors for use as soil nails include:</p> <ul style="list-style-type: none">• Quicker Installation - Screw anchors can be drilled into the ground in a matter of minutes.• Immediate Reinforcement - With screw anchors, soil reinforcement is available immediately upon installation. There is no need to wait for grout to cure.• No Specialized Equipment Required - Screw anchors can be installed using almost any drill motor with sufficient torque output that can be attached to a backhoe, skid loader or trackhoe.• Screw Anchor Capacity Determined During Installation - The capacity of a screw anchor can be estimated directly from the torque required to install the anchor (Hoyt & Clemence, 1989). This provides immediate feedback to determine if design requirements are being met in the field, and eliminates expensive and time-consuming load tests.• With the introduction of the SOIL SCREW® Retention Wall System, soil nailing can be performed without the need for specialized equipment and grouting, and it can be performed quicker and more economically.
--

Screw Anchor Soil Nails

Screw anchor soil nails are screw anchors which consist of 1.5 inch square solid steel shafts, on which steel bearing plates or helices are welded at regular intervals (Figure 1.2.4). The steel used is a high-strength alloy that is specifically formulated to resist the installation stresses associated with the high torque applied to the anchors during installation. The spacing of the helices is a function of the helix diameter, and is typically about 3.6 times the helix diameter, thus insuring each individual helix acts in bearing without affecting adjacent helices. Screw anchor soil nails screw into the soil and obtain their bond with the soil through the bearing of the helices against the soil.

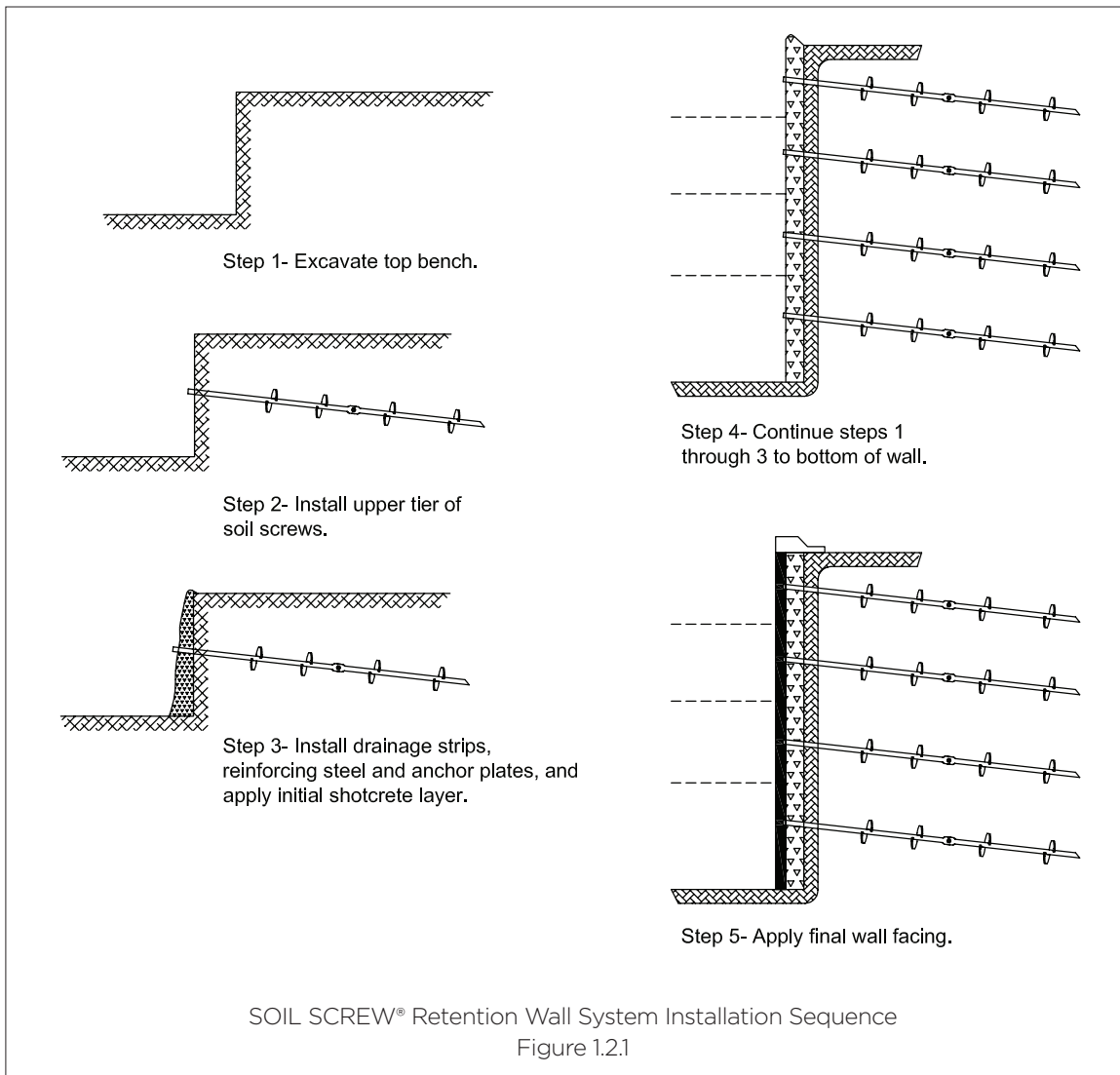

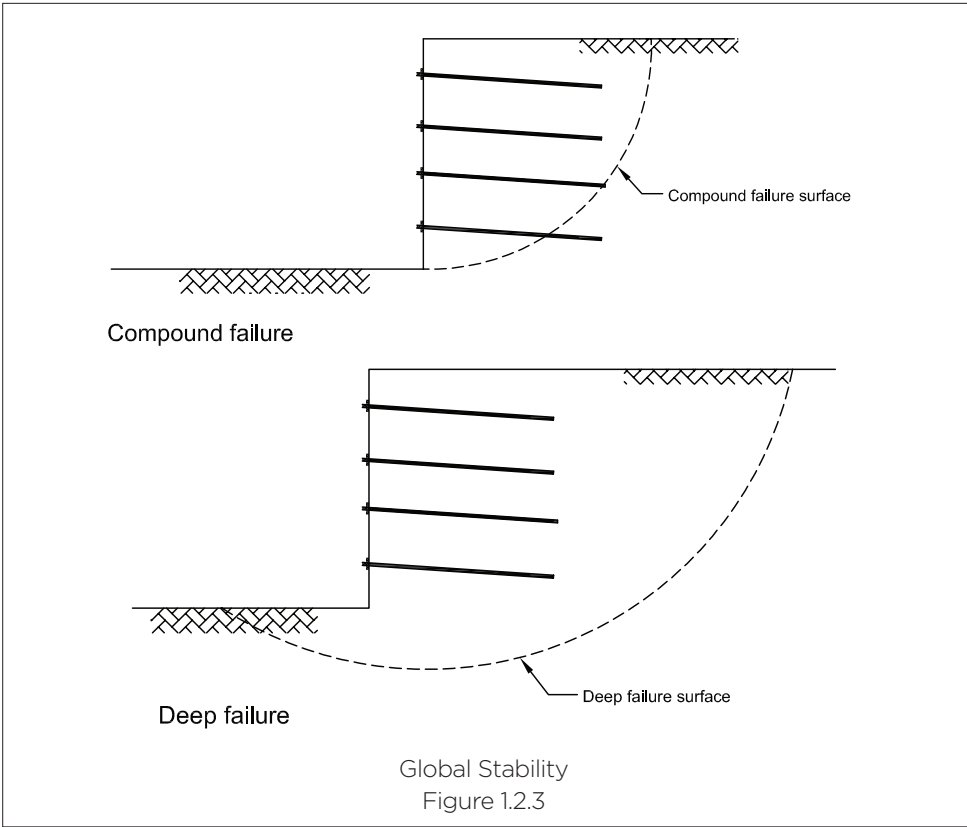
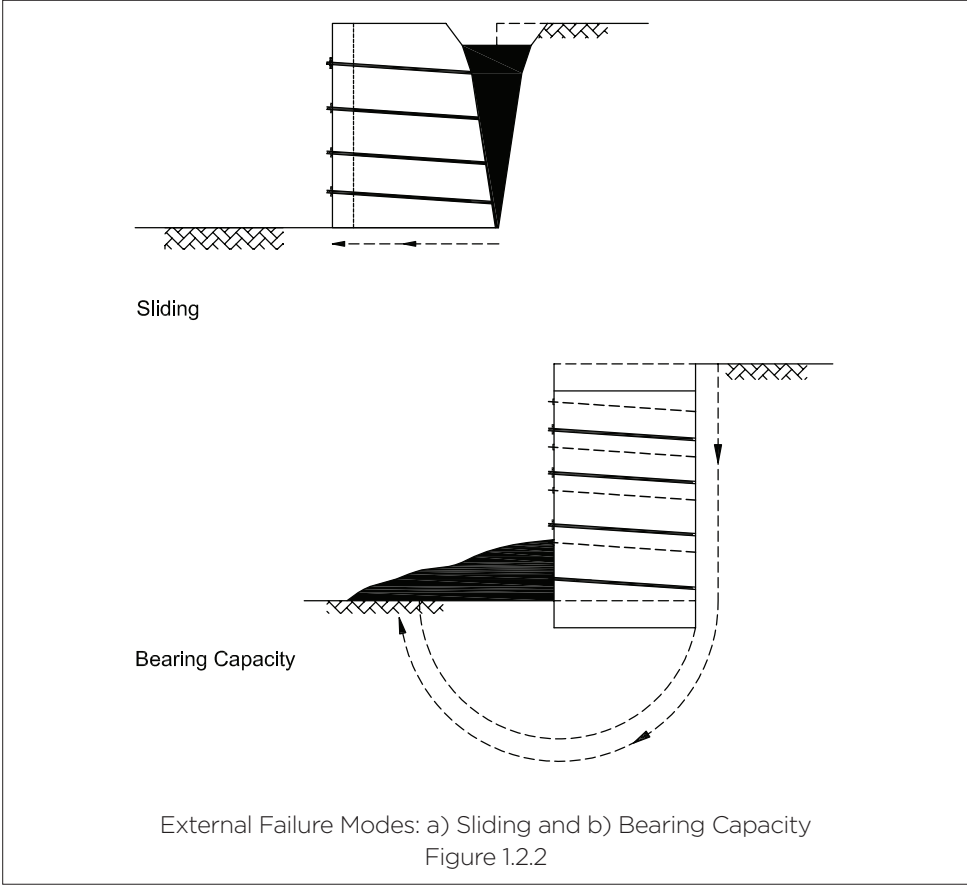

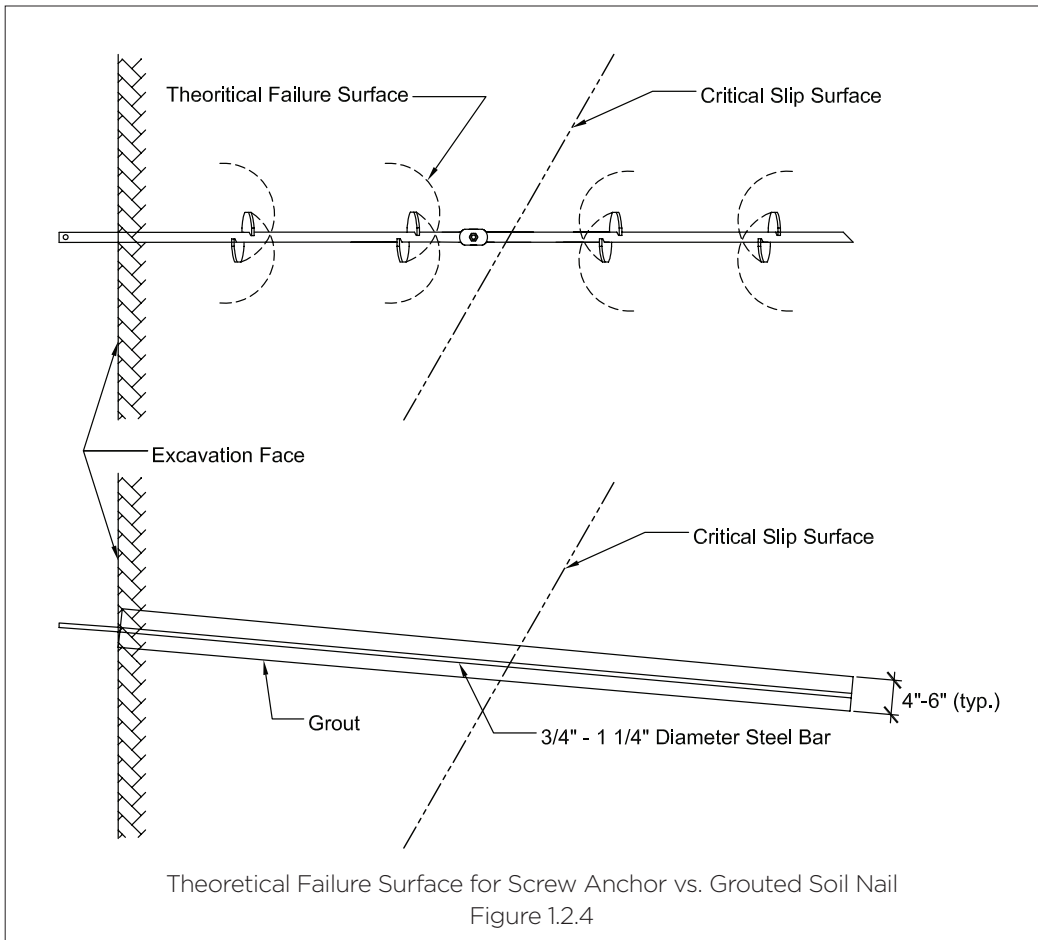

Grouted Soil Nails

Grouted soil nails typically consist of 0.75 inch to 1.25 inch diameter deformed steel bar that is placed in a drilled hole and grouted in place (Figure 1.2.4). The grouted soil nail hole typically has a minimum diameter of 4 inches. Centralizers are placed around the soil nail to maintain an even thickness of grout around the bar. For permanent applications, nails may be epoxy-coated or provided with a protective sheath for corrosion protection

Comparison with Tieback Walls

Soil nail walls are often confused with tieback walls. However, tieback walls are very different (Figure 1.2.5). A tieback wall is constructed by placing structural facing elements, typically steel soldier beams, vertically, or near vertically, at the face of the wall to be constructed. The facing system is anchored to the earth using very high-strength steel tendons or anchors. The design of a tieback wall requires that the wall facing be structurally stiff enough to retain the earth without excessive deformation. Likewise, the anchors need to be installed deep enough and need to be tensioned to a high enough load to be able to support the facing without creep of the anchors with time. Anchors are spaced as widely apart as the stiffness of the facing will allow. The design also requires that the facing element be embedded a sufficient depth to mobilize the passive resistance of the soil to resist facing movement at the toe of the wall during and after construction. The structural facing is “pre-loaded” when the anchors are tensioned. The length of the tiebacks will vary based on their position in the wall and the wall height.

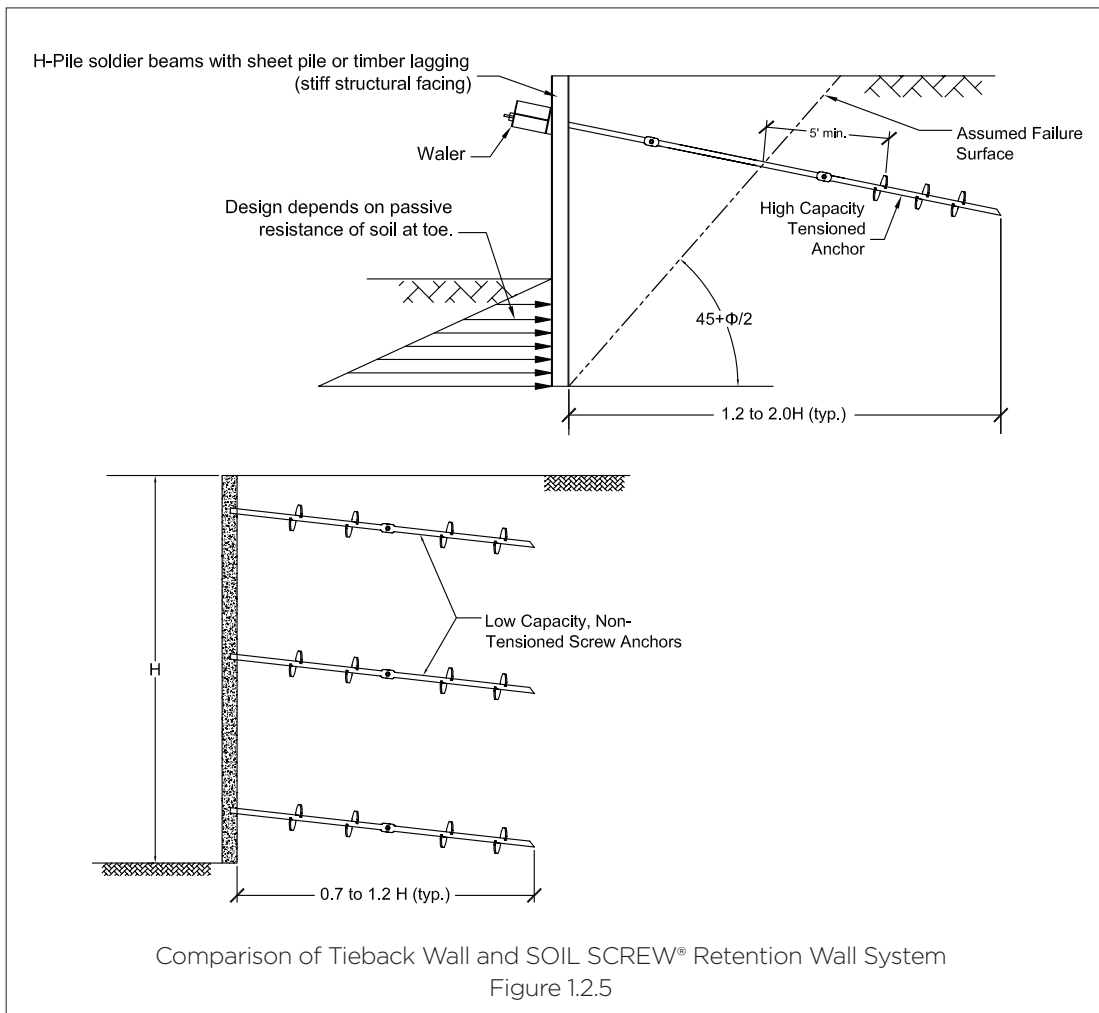

Soil nail walls are quite different. Soil nails are not tensioned. They are passive soil reinforcements that are placed in sufficient quantities within the soil to create a coherent gravity mass. The soil nails have a lower load requirement than tieback anchors, and are placed closer together, typically on the order of 5 foot on center (i.e., 4 to 8 soil nails typically replace one tieback). The soil nails are normally of a uniform length, with the actual length on the order of 70 to 100 percent of the wall height, depending on the soil strength and surcharge conditions. The objective of soil nailing is to create a reinforced soil mass that has sufficient internal stability and size so that it can provide sufficient safety factors against movement due to sliding, bearing failure or global instability. The objective of the facing is to retain soil and to provide enough structural capacity to insure that the nail head will not shear through the facing and that the facing will not fail in flexure between nails.

Comparison with Mechanically Stabilized Earth Walls (MSE)

The design of soil nail walls is often compared to the design procedures for MSE walls. While the mechanics for designing MSE walls are quite similar to soil nail walls, the way in which the reinforcements are tensioned and the location of deformations within the wall are quite different. MSE walls utilize a high density of soil reinforcements. Reinforcements are placed within a controlled compacted granular fill and are attached to a concrete facing panel to retain the soil. In an MSE wall, the reinforcements are passive soil reinforcements with lengths typically varying from 70 to 100 percent of the wall height, depending upon soil strength and loading conditions. The density is somewhat greater than soil nails (i.e., steel strip soil reinforcements used for MSE walls are typically placed on 2.5-foot centers). The strength of steel strip reinforcement is approximately 25% of the strength of a typical soil nail. Both an MSE wall and a soil nail wall require a certain amount of movement to mobilize the strength of the reinforcements. In an MSE wall, reinforcement strength is mobilized by compression of the fill. The stress continues to increase on the reinforcements in the lowest portion of the wall as each additional soil lift is compacted. This places the greatest stress on the lower reinforcement strips, and results in a tendency for deformation, if it occurs, to be observed in the lower third of the wall (Figure 1.2.6). Since a soil nail wall is built from

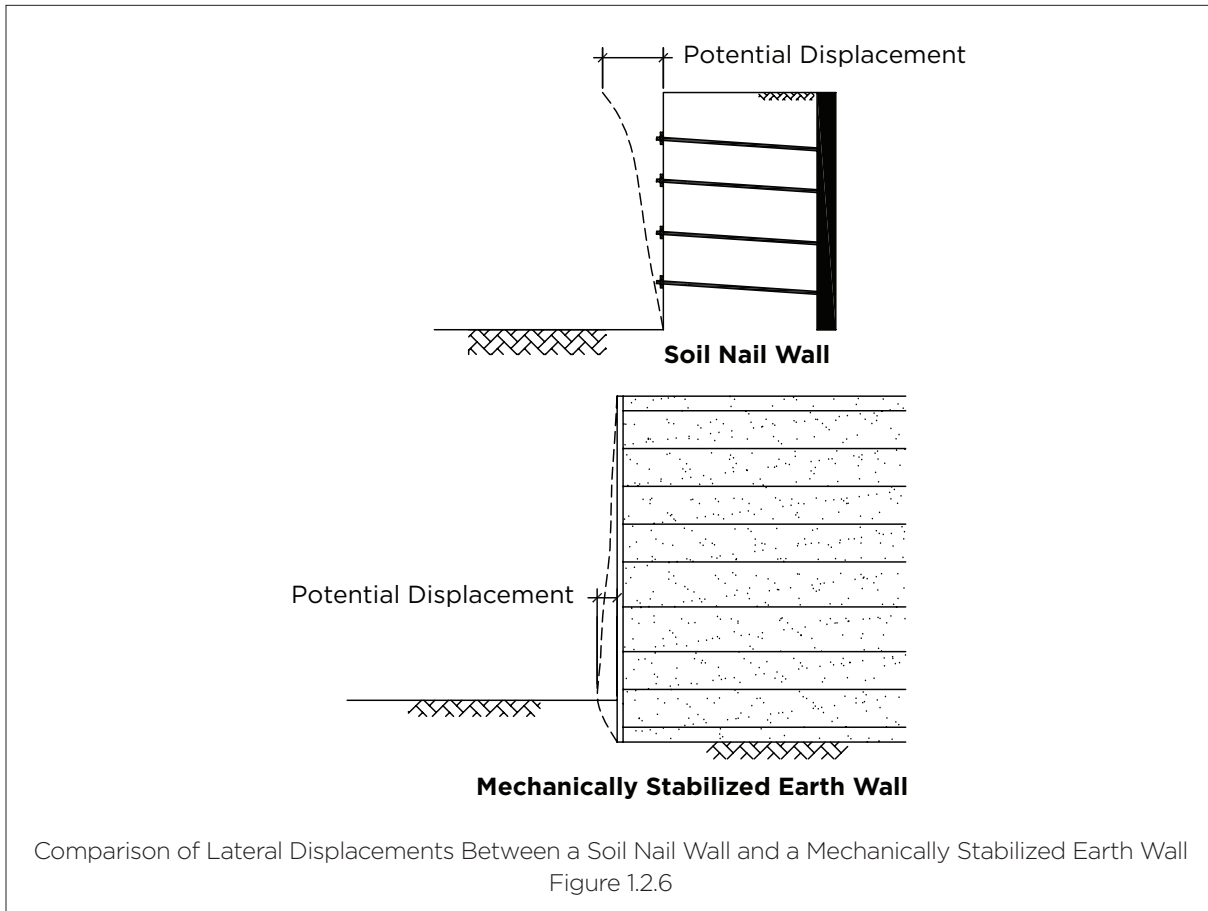

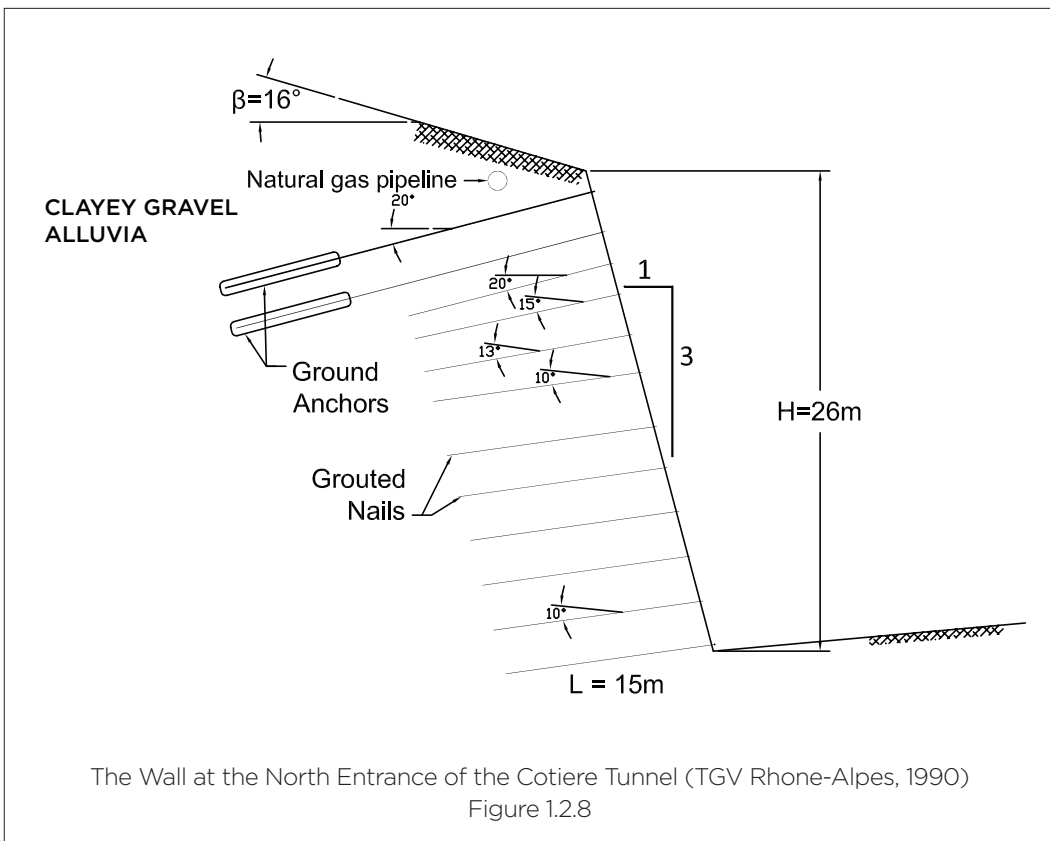
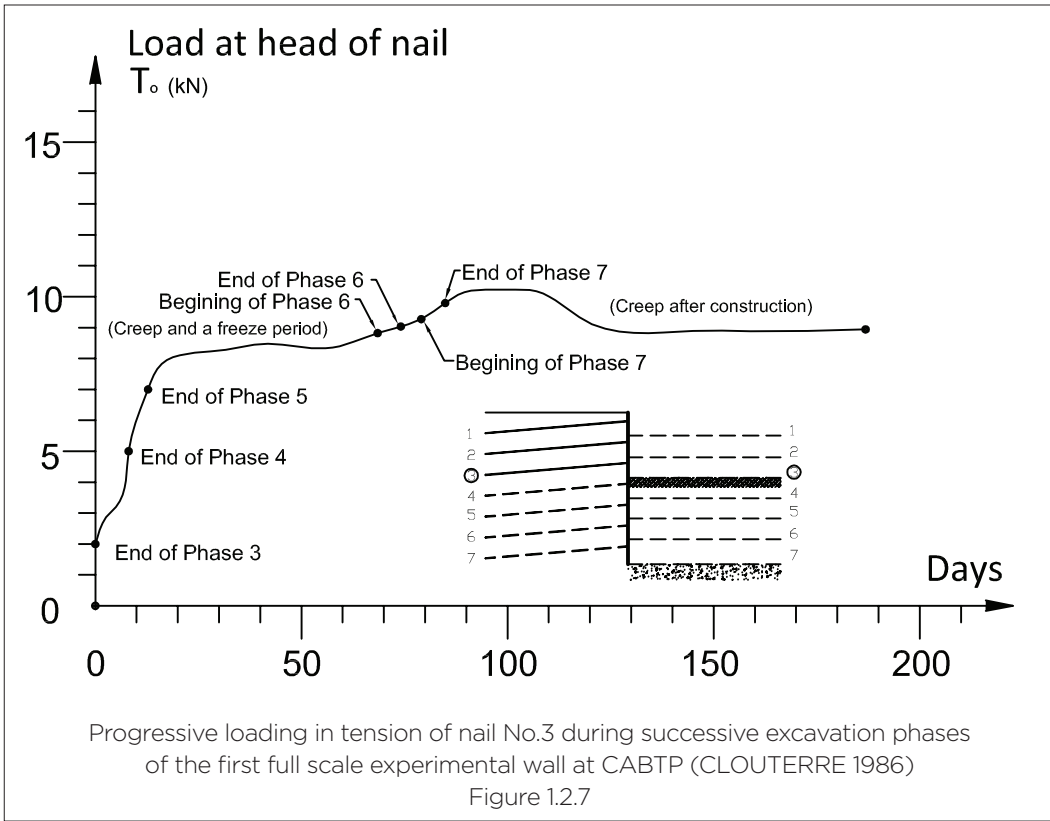

the top down, the first row of nails will exhibit the greatest stress. As soil is excavated at the wall face, the strength of the upper nail is mobilized as a result of the decompression or reduction in confinement of the soil (Figure 1.2.7). For soil nail walls, mobilization of tension in the reinforcements is greatest at the top of the wall initially, and increased tension occurs during excavation of subsequent soil layers. Soil nails must be placed deep enough and at a great enough density to resist these stresses and the resulting deformation during and after construction. Often times the upper row of nails will be placed deeper than the lower row of nails and be pre-tensioned or be placed in combination with a tieback to control facing deformation (Figure 1.2.8). Immediately after construction, the lowest row of nails will have the least amount of tension. However, the tension within the lower row of nails ultimately increases to an equilibrium state over time as stress is transferred from the soil to the reinforcements. Despite the differences in how tension is developed in the reinforcements, the lines of maximum tension in soil nail walls and MSE walls are very similar. Therefore, the reinforcement densities and lengths will be similar.

SOIL NAIL APPLICATIONS

Soil nail walls have been found to be an economical solution to many soil reinforcement and excavation support problems. The following section lists some of the typical applications for soil nail walls and some of their benefits.

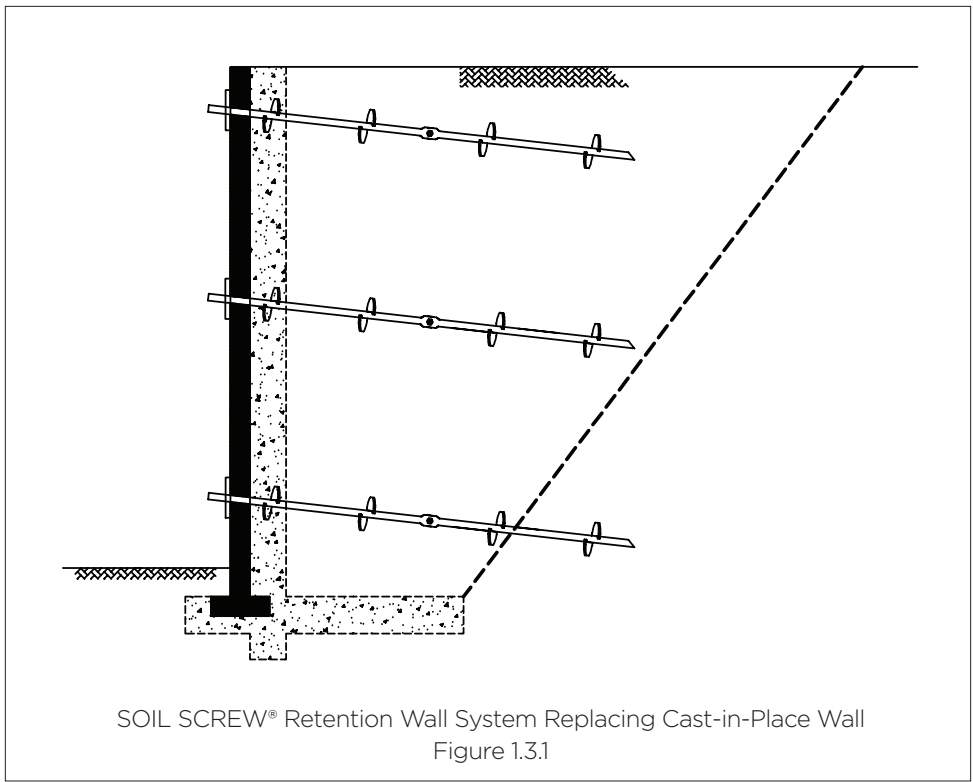

Alternative to Tieback Wall for Temporary or Permanent Excavation Support

- Eliminates the time and expense of placing H-piles.
- Eliminates labor associated with placing timber lagging or sheet piling.
- Eliminates the need for expensive structural facing systems.
- By placing a structural face on a soil nail wall, it can be used as the permanent foundation wall, saving the time and money associated with an additional construction step.
- Decreases right-of-way requirements, since the length required for soil nails is shorter than that for tiebacks.

Alternative to Cast in Place Walls (CIP) in Cuts

Cast-in-place walls in cuts will require temporary shoring and over excavation to be able to install wall footings. A soil nail wall requires no shoring and can use a smaller footing (Figure 1.3.1).

Repair and Reconstruction of Existing Retaining Wall Systems

Replacement and reconstruction of a failed timber or concrete crib wall, MSE wall, gabion wall, or CIP wall is very expensive. An alternative is to reinforce the failed wall with soil nails and replace or repair the facing. This eliminates a very expensive construction step of excavating the failed wall, especially if the wall is supporting another structure (Figure 1.3.2).

Roadway Widening under Existing Bridges

Soil nail walls can eliminate construction steps associated with temporary and permanent walls needed for widening roadways adjacent to existing highway bridges. Soil nail walls can be combined with permanent facings, thus providing a permanent wall for support of bridge fills without the need for temporary shoring by using top down construction sequence (Figure 1.3.3).

Landslide Remediation

Soil nail walls can be used to reinforce failed slopes and walls in-situ. Soil nails must be drilled beyond the failure surface to a depth great enough to mobilize the nail tensile strength. This analysis is similar to the design of a reinforced fill slope, however, soil nails enable this remediation to be performed in-situ without removal and replacement (Figure 1.3.4).

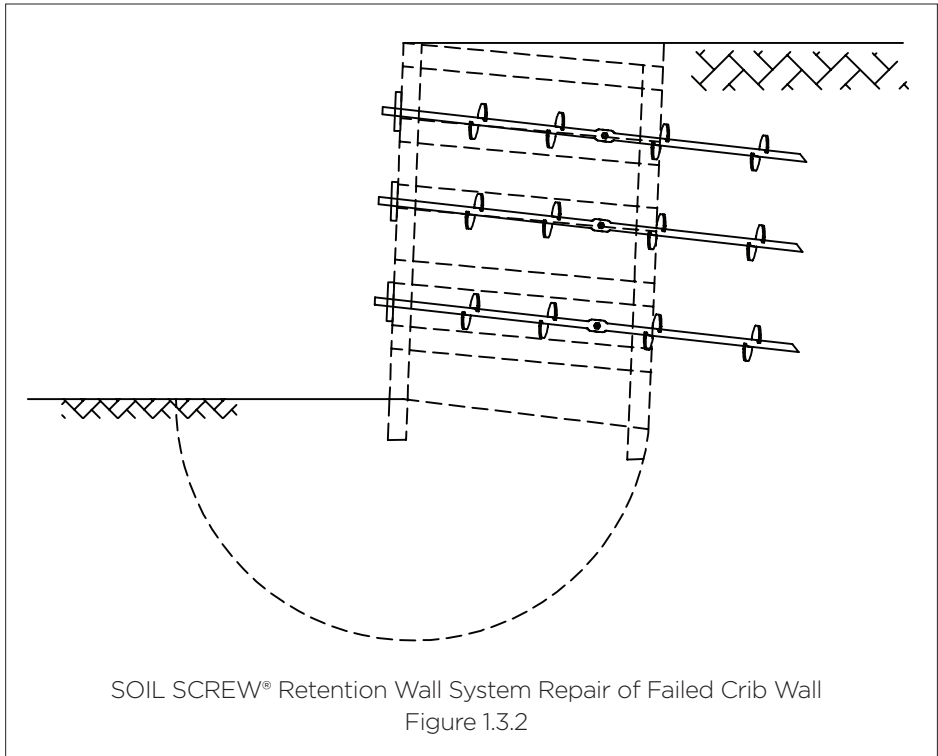

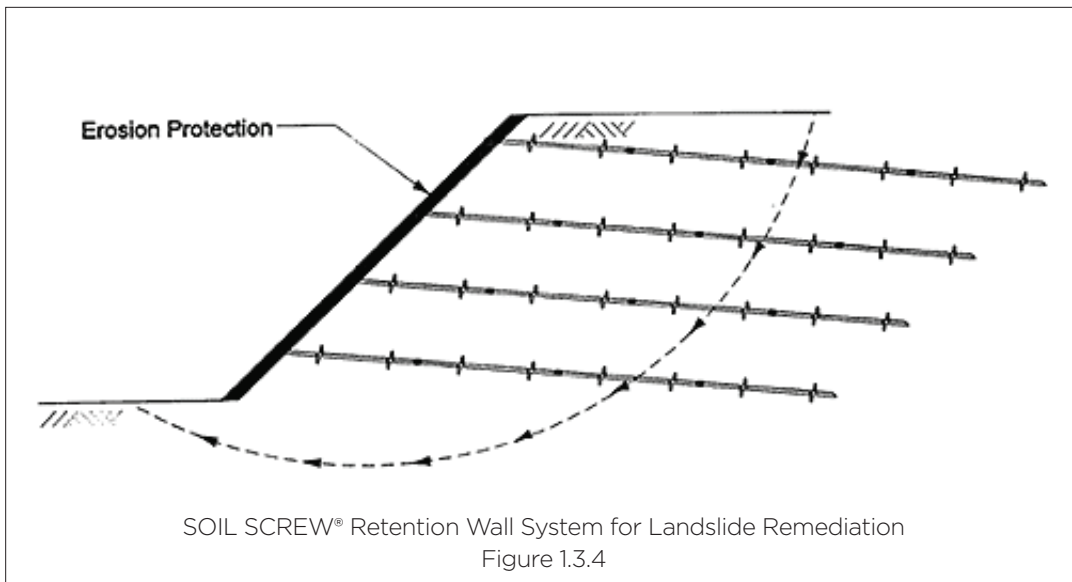
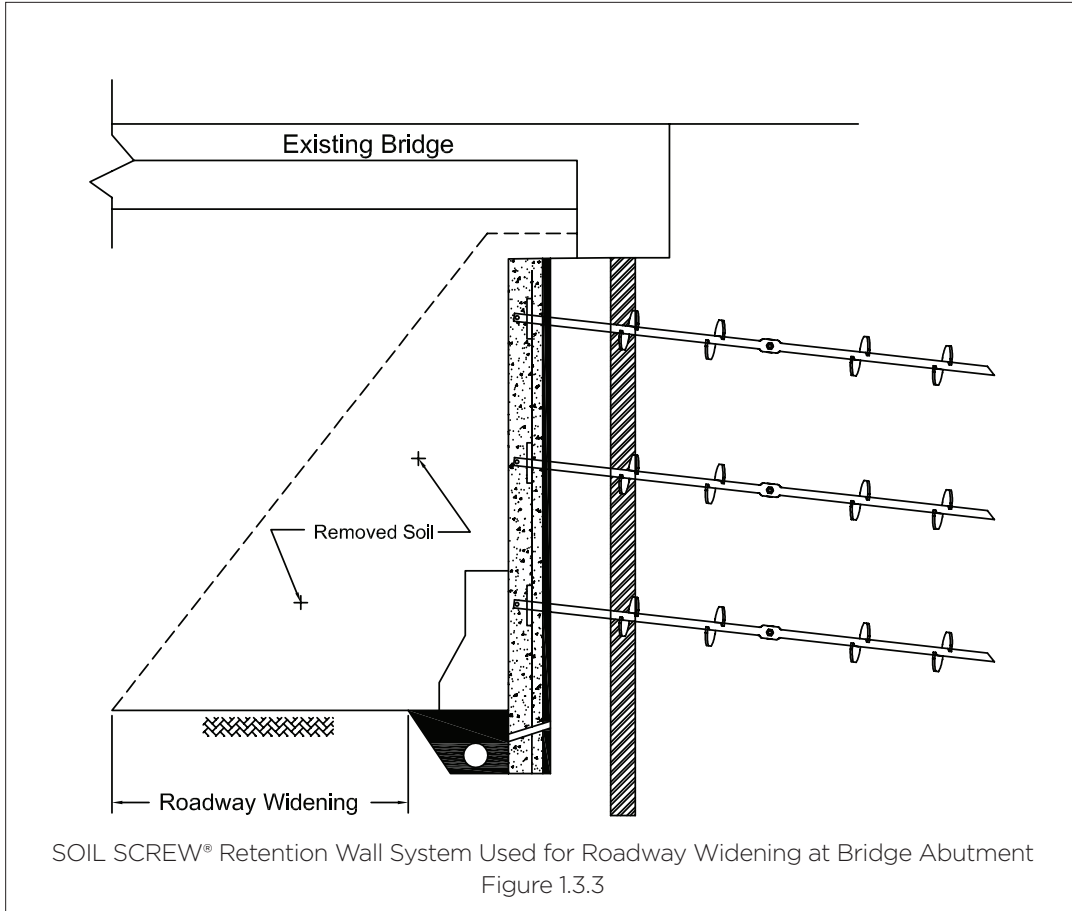

ADVANTAGES OF SOIL NAIL WALLS

Soil nailing provides many of the same benefits as tieback walls. Some of the key advantages of soil nailing are:

- Lower cost, quicker construction process and less impact on adjacent properties when compared to over excavation and construction of a conventional retaining wall.
- Compared to Tieback Walls the advantages of Soil Nailing include:
- Elimination of the need for a high-capacity structural facing (H-Piles, walers or thick CIP facings). In many cases, this lowers cost and construction time.
- Smaller reinforcing elements can be installed with smaller equipment. There is no need for large equipment to drill or drive H-piles, thus allowing more flexibility, even in areas with overhead obstructions.
- Reduced right-of-way requirements, since soil nails are shorter than tiebacks.
- Reduced construction time, since H-piles are not required, and soil nails do not require post-tensioning.

Screw anchor soil nails provide the following advantages over grouted soil nails:

- Reduced manpower, since the steps of nail installation in the drill hole and grouting are eliminated.
- Reduced equipment requirements, since screw anchors can be installed using simpler, less expensive equipment (i.e., backhoe or trackhoe), and no grouting equipment is needed.
- Reduced construction time since installation is quicker, construction steps are eliminated and screw anchors provide required capacity immediately upon installation.
- No spoils, cleaner jobsite.

LIMITATIONS

Soil nailing, along with other in-situ reinforcement techniques, share the following limitations:

- Permanent underground easements may be required.
- Reinforcements may interfere with existing or future utilities.
- Use of soil nails in soft, cohesive soils subject to creep may not be economical, even at low load levels
- Horizontal displacements may be greater than those associated with tieback construction, and therefore, may limit use adjacent to critical structures.
- Shotcrete facings on permanent walls require special drainage considerations to eliminate the potential for freeze-thaw damage, particularly in frost heave susceptible soils such as silts and fine sands.
- Limitations specific to soil nailing construction are:
- For near vertical walls, the soil being nailed must be able to stand unsupported to a height of 3 to 6 feet while it is being nailed and covered with shoring or shotcrete. Alternatively, a construction sequence using slotted cuts, nailing and berming may work, but will add to the cost. Soil without a short-term cohesion, such as loose to medium clean sands and gravels, may not be well suited for soil nailing.
- The groundwater table should be lowered below the bottom of the wall during and after construction. Seepage through the face will soften soils, resulting in local instability or slumping during construction, and reduce the bond between the soil and the shotcrete face. In the long term, the build-up of pore pressure behind the wall and the potential for frost heaving need to be controlled through the placement of permanent drains behind and below the wall face.
- Soil nailing in very low shear strength soil may require a very high soil nail density, and thus be uneconomical.
- Soil nailing in sensitive soils and expansive soils for permanent long-term applications is not recommended. For temporary wall applications in these soils, the potential for loss of shear strength or swelling and heave due to moisture or loadings must be considered.

SOIL NAILING WITH THE SOIL SCREW® RETENTION WALL SYSTEM SECTION 2

CONTENTS

DESIGNING WITH THE SOIL SCREW®	
RETENTION WALL SYSTEM.....	2-3
Facing Deformation	2-3
Pullout Resistance	2-3
Tensile Strength of a Screw Anchor.....	2-3
DATA REQUIRED FOR SOIL NAIL DESIGN	2-3
Soil Parameters	2-4
Surcharges and Loading Conditions	2-5
Drainage and Groundwater Conditions.....	2-5
FACING CONSIDERATIONS.....	2-6
Temporary Facings	2-6
Permanent Facings - Figure 2.3.4	2-8

DISCLAIMER

The information in this manual is provided as a guide to assist you with your design and in writing your own specifications.

Installation conditions, including soil and structure conditions, vary widely from location to location and from point to point on a site.

Independent engineering analysis and consulting state and local building codes and authorities should be conducted prior to any installation to ascertain and verify compliance to relevant rules, regulations and requirements.

Hubbell Power Systems, Inc., shall not be responsible for, or liable to you and/or your customers for the adoption, revision, implementation, use or misuse of this information. Hubbell, Inc., takes great pride and has every confidence in its network of installing contractors and dealers.

Hubbell Power Systems, Inc., does NOT warrant the work of its dealers/installing contractors in the installation of CHANCE® Civil Construction foundation support products.

DESIGNING WITH THE SOIL SCREW® RETENTION WALL SYSTEM

The methodology for designing a soil nail wall using the SOIL SCREW® Retention Wall System is based upon the same limit equilibrium approach used to determine the stability of reinforced soil slopes and the internal stability of mechanically stabilized earth walls. An overview of the design methodology is provided in section 3.3.

Facing Deformation

The fundamental mechanisms and behavior of a soil nail wall reinforced with screw anchors will not differ appreciably from other soil nail systems in that controlling deformation of the wall face requires a skilled and efficient operator during excavation, soil nail installation and placement of the facing. To aid in limiting facing movement, it is common, for all systems, that spacing of the nails in the upper portion of the wall be minimized. And as discussed earlier, providing tiebacks in the upper rows can help to mobilize the soil strength and minimize wall movement. Controlling wall deformations is achieved by using proper installation techniques, a logical design layout and spacing, and by providing tiebacks where deformation control is critical.

Pullout Resistance

The screw anchors used in soil nailing are specially designed with 8-inch helices placed on approximately 2.5-foot centers. This spacing of helices at a distance of more than 3 helix diameters, center to center, helps to ensure that each individual helix acts in bearing without significantly affecting the capacity of the others. For design, the pullout resistance, both in front of and behind a potential failure plane, is analyzed. Design analyses for pullout resistance are provided in section 3.5.2.

One benefit of a CHANCE® screw anchor is that its pullout resistance can also be estimated during installation. Experience with CHANCE® screw anchors has shown that the ultimate capacity of a screw anchor in pounds is approximately equal to 10 times the torque in foot pounds needed to install the anchor. Therefore, monitoring of the torque during soil nail installation can assist in determining soil nail capacity.

Numerous pullout tests have been performed on screw anchors in granular and cohesive soils and have been documented in the literature. These have been summarized for use with the SOIL SCREW® Retention Wall System in section 3.5.2.

Tensile Strength of a Screw Anchor

The ultimate tensile strength of a CHANCE® SS-5 Screw Anchor is 70,000 pounds minimum. This is 2 to 2.5 times greater than the typical soil nail design strength used and is actually controlled by the shear strength of the bolts that connect the shafts. The ultimate tensile strength of the 1½-inch square shaft itself, away from the coupling area, is about 3 times the 70,000 pound strength of the assembly due to the need to resist torsional stresses during installation. The steels used in CHANCE® type SS screw anchors are proprietary alloys designed to resist such stresses.

In determining the actual allowable design strength of a soil nail (Table 3.5.2), both the original tensile strength and the sacrificial steel or loss of cross sectional area over the life of the project, need to be taken into account. The size and strength of CHANCE® Screw Anchors are governed primarily by the strength required to resist torque during installation, and not the tension required for soil reinforcement. Therefore, CHANCE® Screw Anchors provide more-than-sufficient sacrificial steel and tensile strength for long-term performance when compared to the actual design requirements. Calculations and further discussion on how the allowable design strength for CHANCE® Screw Anchor soil nails is developed are provided in section 3.5.1.

DATA REQUIRED FOR SOIL NAIL DESIGN

To perform a soil nail wall design, knowledge of the soil behind the wall face and the foundation soils supporting the wall (Figure 2.2.1) is required. It also requires knowledge of the project geometry, loading and surcharge conditions, groundwater conditions, and the properties of the soil nails.

The purpose of this section is to discuss each of these areas that must be considered prior to performing a design.

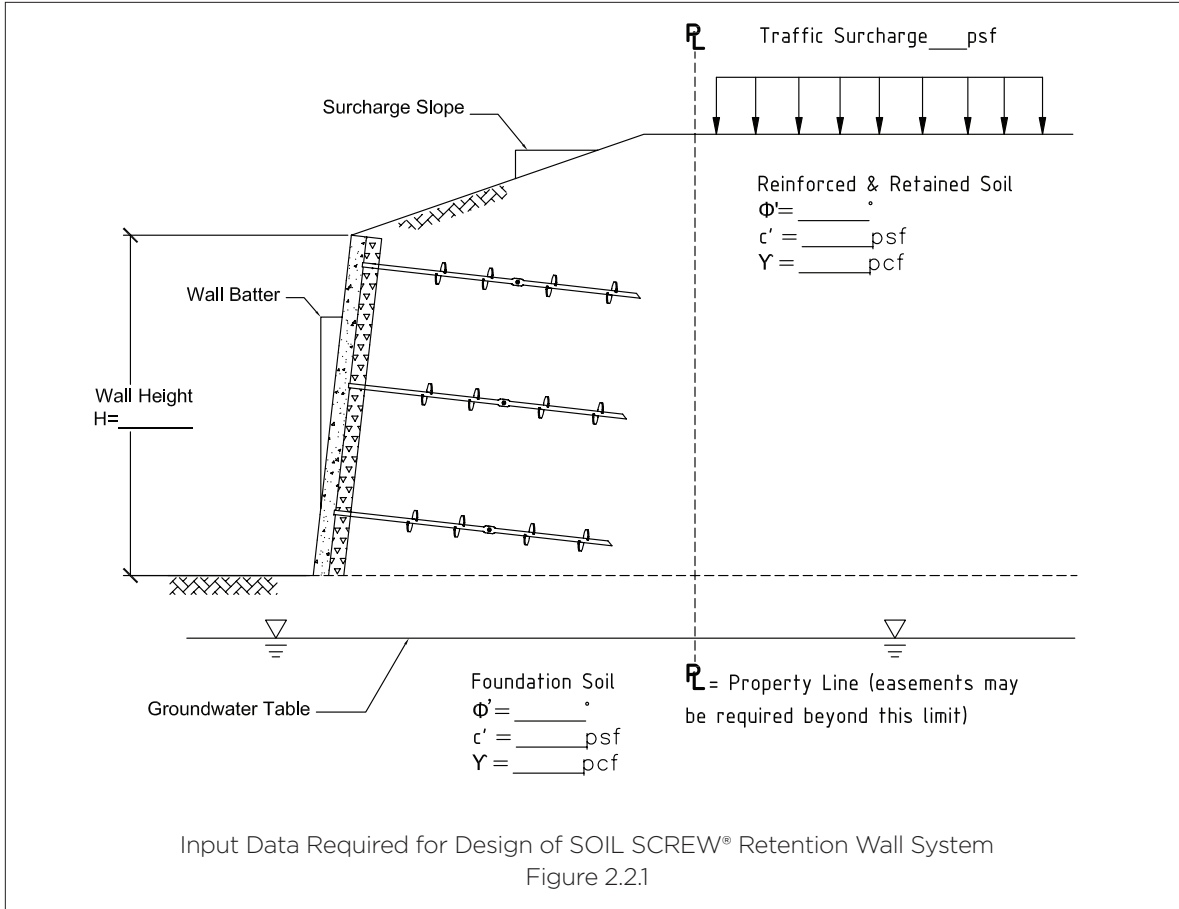

Soil Parameters

As is the case for Mechanically Stabilized Earth Walls (MSE), the quality of a soil nail wall system will be a function of the soil being reinforced. Since a soil nail wall is comprised of over 98% soil, the characteristics of that soil (shear strength, consolidation, permeability, corrosion potential) will greatly influence the soil nail design and the wall performance. The shear strength of the retained soil must also be determined since this will determine what load will be applied to the back of the soil nail wall. The shear strength of the foundation soil will determine what length the soil nails will need to be to resist bearing and sliding failure modes for a wall of a given height.

In general, the key input parameters, in terms of soil properties needed to perform the analyses in section 3.0, are shown on Figure 2.2.1, and are as follows:

Soil Shear Strength - The two components that make up the effective shear strength, s' , of a soil are the internal friction angle (ϕ') and cohesion, c' , of the soil as represented in the equation:

$$s' = c' + \sigma_n \times \tan \phi'$$

Equation 2-1

where: σ_n = effective overburden pressure

The angle at which soil resists shearing is termed its friction angle. The cohesion of the soil is the internal bond within the soil, which is not a function of the overburden pressure. The cohesion may decrease with time in a soil structure, and therefore, oftentimes is ignored in long-term designs.

It is important to accurately determine the friction angle of the reinforced soil, retained soil and foundation soils. The friction angle of the soil is best determined from consolidated undrained triaxial compression tests which measure pore

water pressures and drained direct shear tests performed at rates slow enough to ensure that pore water pressure does not occur during the test. The friction angle of a soil can also be estimated from grain size analyses, standard penetration testing and cone penetration testing for preliminary designs, but is best determined from actual laboratory or field testing for final designs.

The dry and moist density of the soil should also be determined in order to provide an accurate assessment of the loading from each element. These values are best obtained from direct measurements of the soil density and moisture from Shelby tube samples. These values can also be estimated based on prior knowledge of the local soils or from grain size analyses.

Consolidation/Creep – The tendency of a soil nail to creep in soil will be a function of the consolidation characteristics of the soil being reinforced. In general, if the soil is fine grained, the potential for soil nail movements in the long term is greater than that for granular soils. For permanent soil nail applications, soil nailing should not be performed in soils with moderate to high plasticity, such as soils classified as MH or CH, and caution should be used for temporary applications.

Soil Corrosion Potential – The corrosion potential for a soil can be determined by running tests on the resistivity, pH, sulfates and chlorides, as discussed in detail in section 3.5.1. In general, soils with a resistivity of greater than 3000 ohm-cm and a pH between 5 and 10 are good candidates for screw anchor soil nails. Tests as described in Table 3.5.1 should be carried out on the soil to be reinforced to determine if the soil is suitable for nailing.

Surcharges and Loading Conditions

To accurately perform stability analyses for a soil nail wall, the geometry of the wall cross section is required. This includes the slope at the toe of the wall, the top of the wall and the wall batter (if any). Slopes as flat as 3(H):1(V) at the top or bottom of a wall can have a significant effect on the global stability of a wall. Other surcharge loads can include dead and live loads such as:

- Traffic Surcharges
- Railroad Surcharges
- Buildings
- Tiered Walls
- Construction Equipment during and after construction
- Earthquake Loading
- Rapid Drawdown Conditions
- Traffic Barriers, Sound Walls, Bridge Loadings, Lateral Load from Piles
- Blastings

While all of these conditions are not incorporated in the design charts in Section 3, these can be analyzed using commercially available slope stability and soil nail design software, i.e., SNAIL, GOLDNAIL, STABL.

Drainage and Groundwater Conditions

The location of the permanent groundwater table is critical to a successful design. Soil nailing is best suited to applications above the water table. Excess seepage that cannot be controlled by strip drains during construction can deteriorate the excavated face, prevent shotcrete from bonding with the soil and provide excess pressure on the wall face. Therefore, soil nailing may not be feasible in areas where a permanent phreatic surface exists in the proposed wall volume.

Seepage from surface infiltration can be controlled with well-designed drains (Figure 2.3.1), such as a lined interceptor ditch placed at the top of the wall and a subsurface drain placed inside the wall face. Details on drainage design are discussed in section 4.1.4.

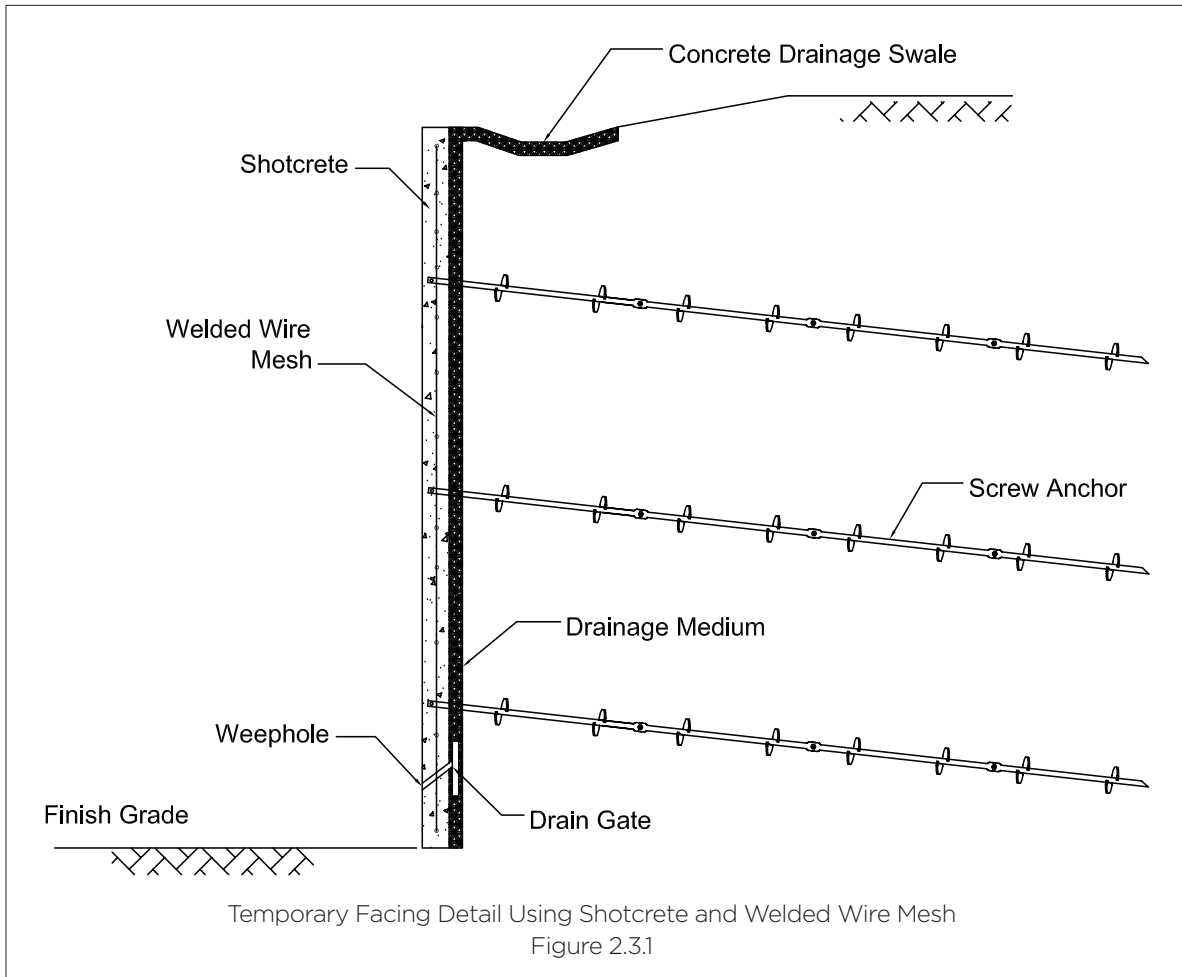

FACING CONSIDERATIONS

Prior to design, the type of facing for temporary and permanent walls needs to be identified. While shotcrete facing is most commonly used, depending upon the site conditions and the ultimate wall batter or slope, there are other options that may be desirable. Each of these is discussed below.

Temporary Facings

Temporary facing systems that can be used with the SOIL SCREW® Retention Wall System include shotcrete and welded wire mesh; welded wire mesh, steel channels and geotextiles; and timber shoring.

The most effective is shotcrete, since it creates a bond with the soil and fills in voids which may develop due to sloughing of soil at the wall face. For projects involving near vertical walls where minimal wall movement is required, this is the best option. Typically a 3 to 4 inch layer of shotcrete is applied. The shotcrete is lightly reinforced with welded wire mesh, as shown in Figure 2.3.1. Drainage can be provided, if needed, between soil nails at less than a 50% area coverage to allow for bond of the shotcrete with the soil.

For sloping walls or for sites where vertical cuts are not required to install soil nails (cut and fill situations), use of a welded wire mesh facing or timber walers may be effective (Figure 2.3.2). In these situations where soils have an apparent cohesion and are cut on a slope, and soil sloughing is not a problem, the facing can be designed to contain the fill rather than provide a structural face to span nails in flexure.

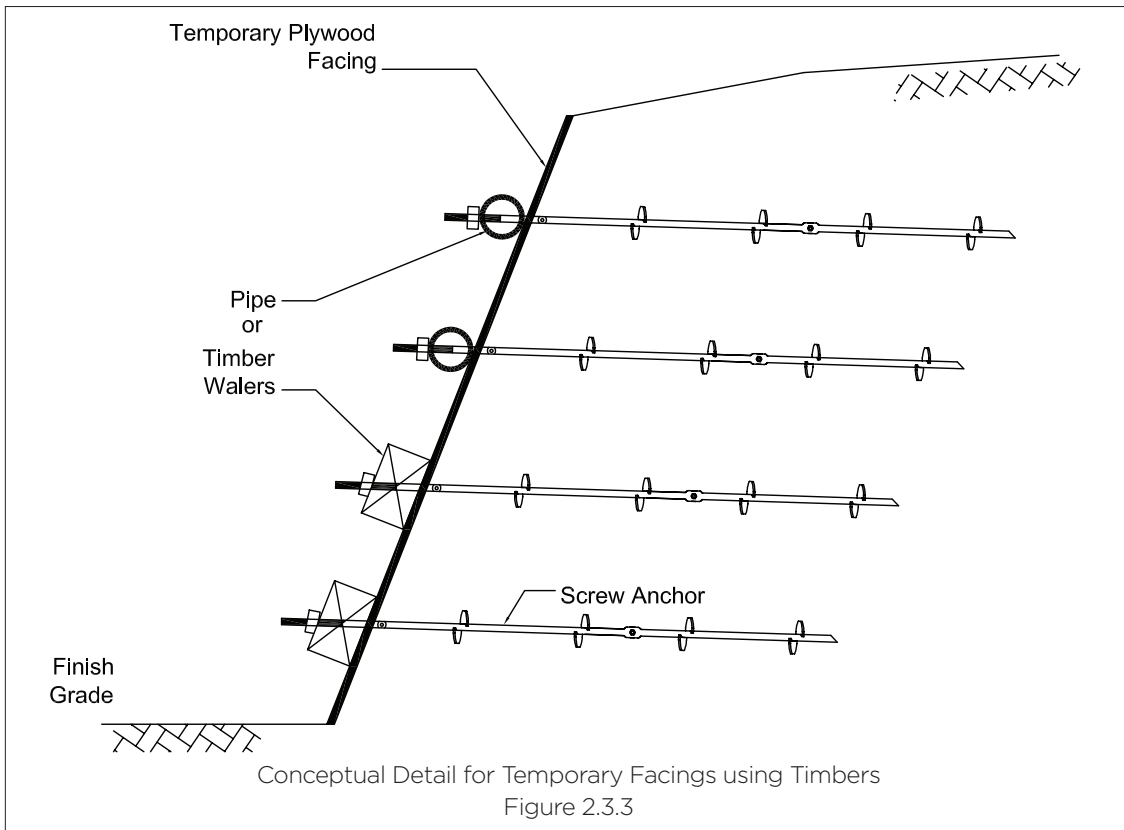
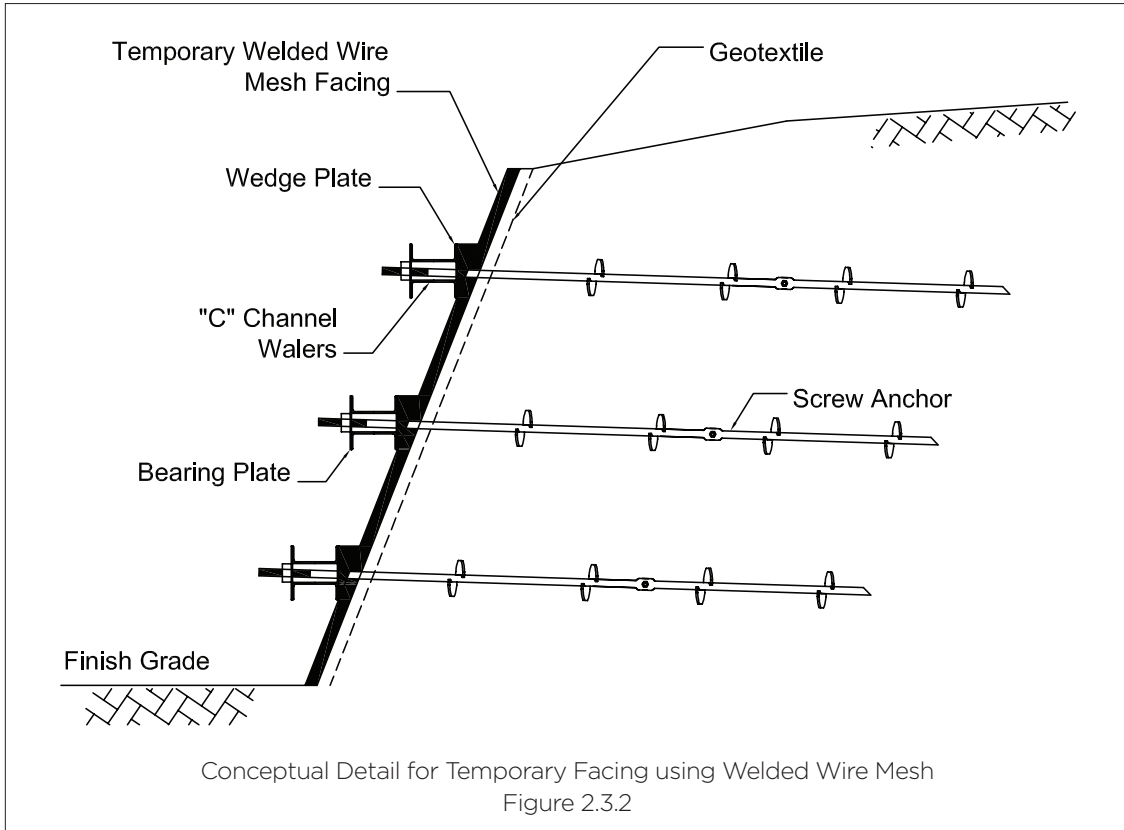

Permanent Facings

Permanent facing systems that can be used with the SOIL SCREW® Retention Wall System for near vertical walls include reinforced shotcrete, cast-in-place and precast concrete panels, concrete masonry segmental wall units (Figure 2.3.3), and gabions.

These facings must be designed to structurally support the soil loading applied between soil nails and be attached with a connector that is strong enough to resist punching failure of the nail at the wall face. The design of the permanent shotcrete or concrete facing for flexural stiffness and punching is adequately covered in FHWA-SA-96-069.

For soil nailed slopes where the slope facing is stable without reinforcements, i.e., the soil nails are being used to increase the deep seated slope stability (Figure 1.3.4), a facing consisting of an erosion mat and vegetation consistent with the area can be utilized.

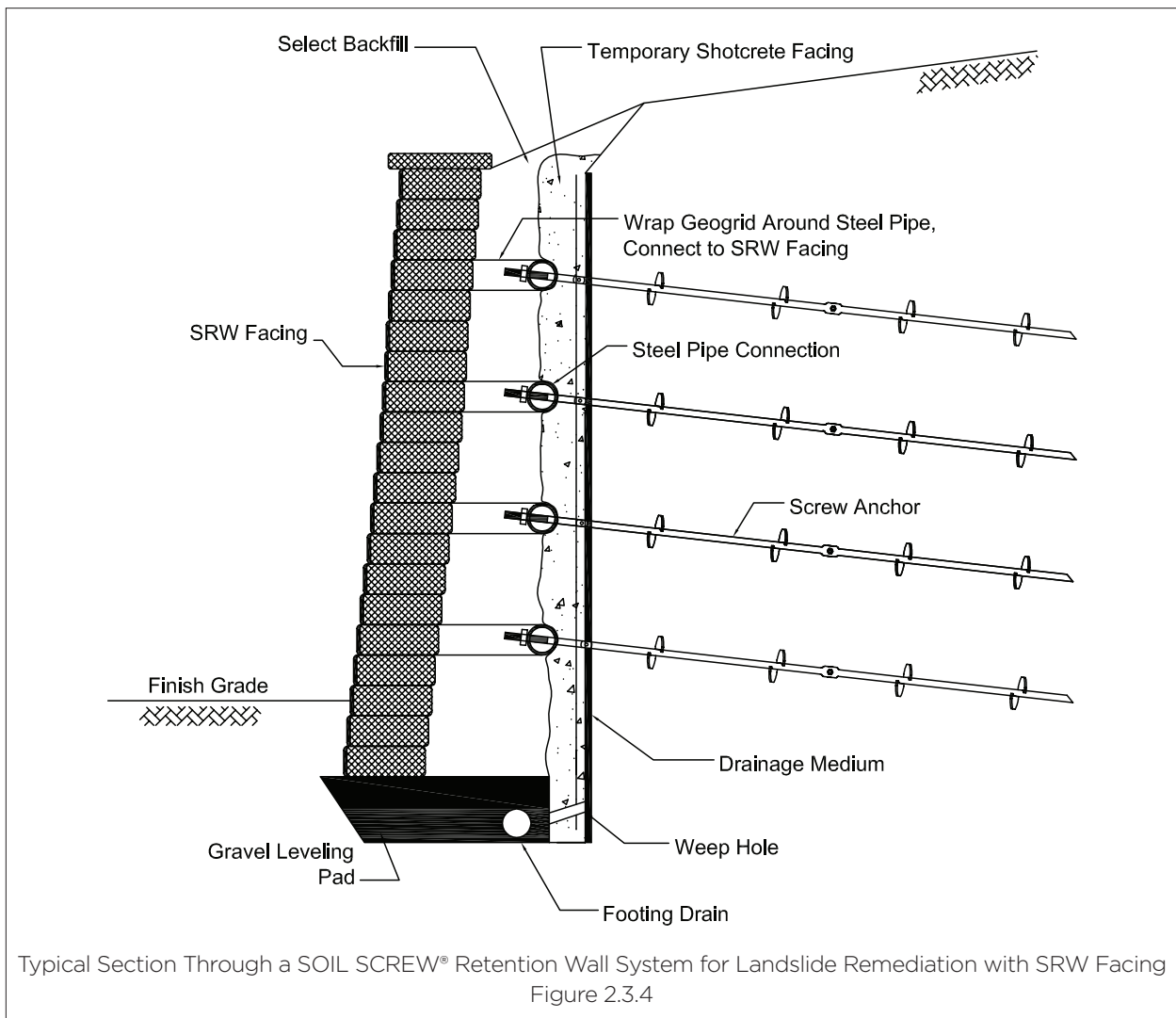

DESIGN GUIDELINES FOR SOIL NAILED WALLS UTILIZING THE CHANCE SOIL SCREW® RETENTION WALL SYSTEM SECTION 3

CONTENTS

DESIGN GUIDELINES

SITE INVESTIGATION	3-4
Regional Geology	3-4
Field Reconnaissance.....	3-4
Subsurface Exploration.....	3-4
Laboratory Testing.....	3-5
PRELIMINARY FEASIBILITY ASSESSMENT	3-5
Ground Conditions Best Suited for Soil Nailing with the SOIL SCREW® Retention Wall System	3-5
Ground Conditions Considered Not Favorable for Soil Nailing Using the SOIL SCREW® Retention Wall System	3-6
Design Charts.....	3-6
OVERVIEW OF DESIGN METHODOLOGY	3-6
EXTERNAL STABILITY	3-8
Earth Pressures for External Stability.....	3-8
Sliding Stability.....	3-11
Bearing Capacity	3-12
INTERNAL STABILITY	3-13
Allowable Nail Strength	3-13
Pullout Capacity of Nail	3-15
Pullout of Screw Anchors in Sands and Silts	3-15
Facing Design	3-17
Flexural Strength of the Facing.....	3-18
Punching Shear Strength of the Facing.....	3-20
Cantilever Design Check.....	3-22
Nail Strength Envelope	3-23
Internal Stability Limit Equilibrium Analysis	3-23

GLOBAL STABILITY	3-24
SUMMARIZED DESIGN STEPS.....	3-24
SPECIAL DESIGN CONSIDERATIONS.....	3-25
Tiered Walls	3-25
Surcharge Loads - Figure 3.8.1.....	3-25

DISCLAIMER

The information in this manual is provided as a guide to assist you with your design and in writing your own specifications.

Installation conditions, including soil and structure conditions, vary widely from location to location and from point to point on a site.

Independent engineering analysis and consulting state and local building codes and authorities should be conducted prior to any installation to ascertain and verify compliance to relevant rules, regulations and requirements.

Hubbell Power Systems, Inc., shall not be responsible for, or liable to you and/or your customers for the adoption, revision, implementation, use or misuse of this information. Hubbell, Inc., takes great pride and has every confidence in its network of installing contractors and dealers.

Hubbell Power Systems, Inc., does NOT warrant the work of its dealers/installing contractors in the installation of CHANCE® Civil Construction foundation support products.

SITE INVESTIGATION

The feasibility of using screw anchors to construct a soil nailed wall on a project depends on the existing topography, subsurface conditions, soil/rock properties, and the location and condition of adjacent structures. It is, therefore, necessary to perform a comprehensive site investigation to evaluate site stability, adjacent structure settlement potential, drainage requirements, anchor capacities, underground utilities and groundwater, before designing a soil nailed earth retention system.

Subsurface investigations must explore not only the location of the face of the soil nailed structure, but the region of the anticipated bond length of the nail. Each project must be treated separately, as both the soil conditions and risks may vary widely. A well-planned site investigation should include a review of the regional geology, a field reconnaissance, a subsurface exploration and laboratory testing. The site investigation should provide adequate information to design a stable soil nailed system.

Regional Geology

A review of the regional geology should be performed prior to conducting a field reconnaissance or subsurface exploration to better understand the geology and groundwater conditions of the region. The information acquired in this first phase of the site evaluation will be used to further develop the field reconnaissance and subsurface exploration. Information concerning the regional geology may be obtained from geologic maps, air photographs, surveys and soils reports for adjacent or nearby sites. Sources of information concerning the regional geology may be obtained from the U.S. Geologic Survey, the Soil Conservation Service, the U.S. Department of Agriculture, and local planning boards or county offices.

Field Reconnaissance

Field reconnaissance should be conducted by a geotechnical engineer or by an engineering geologist. A well planned and conducted field reconnaissance should consist of collecting any existing data relating to the subsurface conditions and making a field visit to:

- Select limits and intervals for topographic cross-sections.
- Observe surface drainage patterns, seepage and vegetative characteristics to estimate drainage requirements. Corrosion of existing drainage structures should be noted to identify if a corrosive environment may exist for shotcrete and/or steel materials.
- Study surface geologic features including rock outcroppings and landforms. Existing cuts or excavations should be used to identify subsurface stratification.
- Determine the extent, nature, and situation of any above or below ground utilities, basements and/or substructures of adjacent structures which may impact explorations or construction.
- Assess available right-of-way.
- Determine areas of potential instability, such as deep deposits of weak cohesive and organic soils, slide debris, high groundwater table, bedrock outcrops, etc.

Subsurface Exploration

The subsurface exploration program may consist of soil borings, test pits, cone penetration tests, soil soundings, etc. The number, type, and location of the subsurface explorations are usually determined by the geotechnical engineer, based on the results of the field reconnaissance. The exploration must be sufficient to evaluate the geologic and subsurface profile in the area of construction. For guidance on the extent and type of required investigation, the 1988 AASHTO Manual on Foundation Investigations is recommended. The following minimum guidelines are suggested for the subsurface exploration for a soil nailed wall using screw anchors:

- Soil borings should be performed at intervals of 100 feet along the alignment of the soil nailed wall face and 150 feet along the back of the reinforced soil structure. The width of the soil nailed structure may be assumed as 1.0 times the height of the wall. For sloping ground conditions behind the wall face, the width of the soil nailed structure may be assumed to be 1.5 times the wall height.

- The boring depth should be controlled by the general subsurface conditions. In areas of where rock is not encountered, the boring should extend at least to a depth equal to twice the height of the earth structure. Where bedrock is encountered at a reasonable depth, rock cores should be obtained for a length of approximately 10 feet. This coring will be useful in distinguishing between solid rock and boulders.
- In each boring, soil samples should be obtained at 5 foot intervals and at changes in strata for visual identification, classification, and laboratory testing. In each boring, careful observation should be made for the prevailing groundwater table, which should be observed at the time of sampling but also at later times to obtain an understanding of the change in groundwater table with time.
- Additional information from in-situ testing such as dilatometer, and pressuremeter may be conducted to provide soil modulus values.
- Obtain bulk samples of the subsurface soils to be used in the laboratory testing program.
- Test-pit explorations should be performed to help assess whether or not the excavated face will stand while temporarily unsupported during the stage of excavation prior to shotcreting the face.

Laboratory Testing

Soil samples should be visually examined and appropriate tests performed for classification according to the Unified Soil Classification System (ASTM D 2488-69). These tests will permit the engineer to decide what further tests will best describe the engineering behavior of the soil at a given project site. Index testing includes determining the moisture content, Atterberg limits, compressive strength and gradation.

Shear strength determination from unconfined compression tests, direct shear tests, or triaxial compression tests will be needed for the stability analysis. Both undrained and drained (effective stress) strength parameters will be needed for cohesive soils to permit evaluation of both long-term and short-term conditions.

Properties to indicate the potential aggressiveness of the in-situ soil within the reinforced zone should be measured. The tests include: pH, electrical resistivity, and salt content (sulfate, sulfides, and chlorides). These test results will provide necessary information for planning degradation potential and protection.

For more information on the development of a site investigation for a soil nailed system or any other mechanically stabilized earth system, the following references are recommended: FHWA-SA-96-069 Manual for Design & Construction Monitoring of Soil Nail Walls, and FHWA-SA-96-071 Mechanically Stabilized Earth Walls and Reinforced Soil Slopes Design and Construction Guidelines.

PRELIMINARY FEASIBILITY ASSESSMENT

Based on the results of the site investigation, a preliminary feasibility evaluation can be made to determine if a successful soil nail design can be implemented with a relatively high degree of confidence. The ground conditions for which soil nailing is well suited and the ground conditions that are problematic are presented in the following sections.

Ground Conditions Best Suited for Soil Nailing with the SOIL SCREW® Retention Wall System

The economical use of soil nailing using the SOIL SCREW® Retention Wall System requires that the ground be able to stand unsupported in a vertical or near vertical cut of 4 - 6 feet in height for one or two days. In addition, the screw anchors must be able to penetrate the ground at a rate compatible to the pitch of the helices. The following ground types are considered most favorable for soil nailing using the SOIL SCREW® Retention Wall System:

- Naturally cemented or dense sand and gravel.
- Residual soils and weathered rock (SPT values < 35 blows per foot) without unfavorable oriented joints or low shear strength.
- Sands with some “apparent cohesion,” due to capillary effects, of at least 100 psf.
- Stiff cohesive soils such as clayey or sandy silts and low plasticity clays that are not susceptible to creep.
- Soils above the groundwater table.

Ground Conditions Considered Not Favorable for Soil Nailing Using the SOIL SCREW® Retention Wall System

Soil nailing is not well suited for all soil types and ground conditions. Generally, when the soil type and ground conditions make the installation of the screw anchors difficult, or the standup time of the excavation face is not sufficient enough to allow the application of the shotcrete, soil nailing should not be used. The following ground conditions are considered unfavorable for soil nailing with screw anchors:

- Rock or decomposed rock, with SPT values > 35 bpf. These are materials in which installation of screw anchors is difficult.
- Decomposed rock with joints and/or discontinuities that are inclined steeply toward the excavation face.
- Loose clean sands with SPT values < 10 bpf. This material will generally not exhibit adequate standup time. These materials may also be susceptible to large volume changes (e.g. densification) due to vibrations from construction equipment.
- Poorly-graded, cohesionless soil (coefficient of uniformity < 2) may tend to ravel when exposed, due to lack of apparent cohesion.
- Soils that contain pockets of high moisture content or saturated material (e.g., no apparent cohesion) that will slough and create face stability problems when exposed.
- Organic soils
- Clay soils with a Liquidity Index greater than 0.2 and undrained shear strength less than 1000 psf may continue to creep significantly over the long term.
- Moisture sensitive soils (i.e., high frost-susceptible and expansive soils). Moisture changes in these soils can result in a significant increase in nail loading at the face of the wall.

A preliminary assessment of the applicability of soil nailing with the SOIL SCREW® Retention Wall System can be determined using the parameters outline in Sections 3.2.1 and 3.2.2, together with FHWA-SA-96-069.

Design Charts

The design charts provided in this manual are to assist in determining only the feasibility of using a SOIL SCREW® Retention Wall System, and should not be used for actual designs. Appendix A contains design charts for soils with effective friction angles that vary from 25° to 35°. The charts are based on an internal factor of safety of 1.5. For a given design height and nail spacing, a preliminary nail length may be determined. The example problem in Appendix A demonstrates how these tables should be used.

OVERVIEW OF DESIGN METHODOLOGY

The design procedure presented in this manual draws heavily on two FHWA documents: Mechanically Stabilized Earth Walls and Reinforced Soil Slopes Design and Construction Guidelines (FHWA-SA-96-071), and Manual for Design & Construction Monitoring of Soil Nail Walls (FHWA-SA-96-069). The design is based on a limit equilibrium design approach that combines conventional reinforced slope design requirements with reinforced soil wall design methods.

The design of any soil nail wall must consider internal, external, and global stability, and the ability of the facing system to support the face of the excavation between nails. External stability of the soil nail wall is concerned with the ability of the reinforced soil mass to withstand the earth pressures and surcharge loads exerted on the composite material from the retained soils. The modes of failure for external stability are sliding and bearing capacity (Figure 3.3.1). Global stability; failure surfaces that pass entirely outside the reinforced soil mass; and compound failures, failures that pass partially through the reinforced soil mass and partially outside the reinforced soil mass, must also be considered (Figure 3.3.2). Internal stability considers the ability of the reinforced soil mass to act as a coherent gravity structure. Figure 3.3.3 shows the modes of failure for internal stability. They consist of pullout of the nail from the resisting zone of the composite material, and rupture of the reinforcement. Finally, the facing and the connection between the facing and nail must be evaluated.

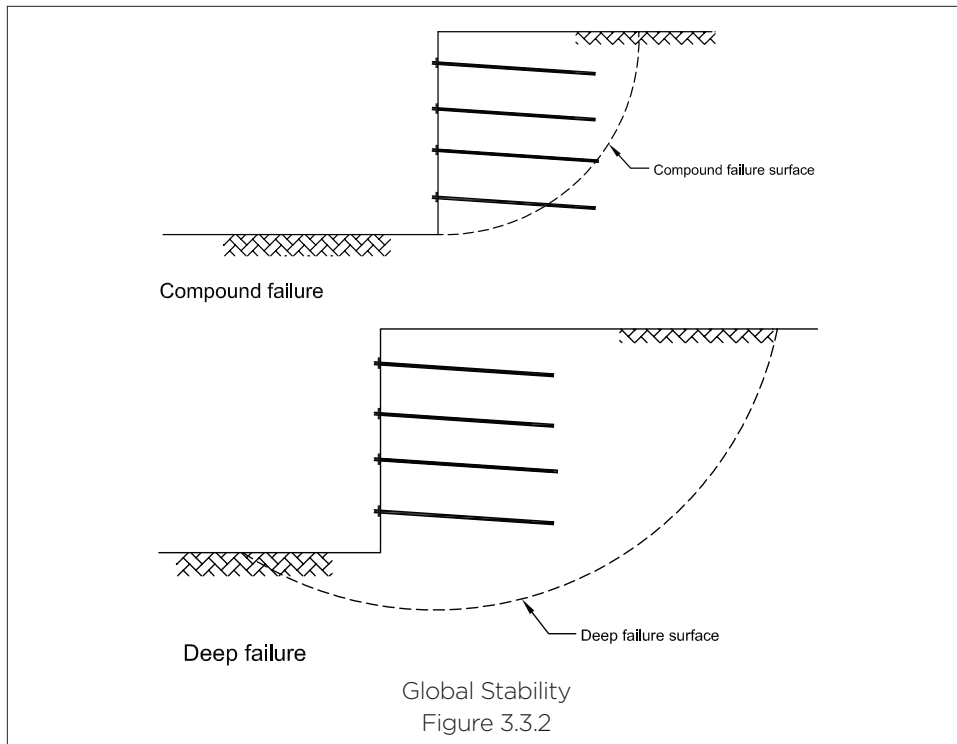
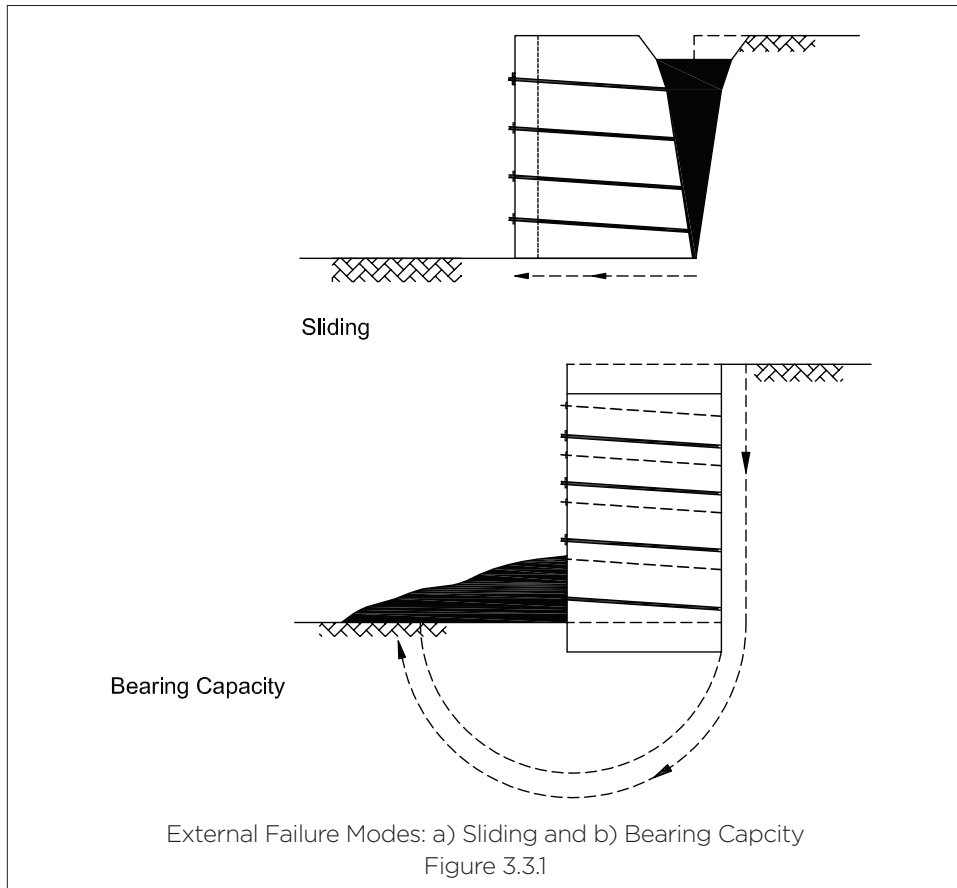

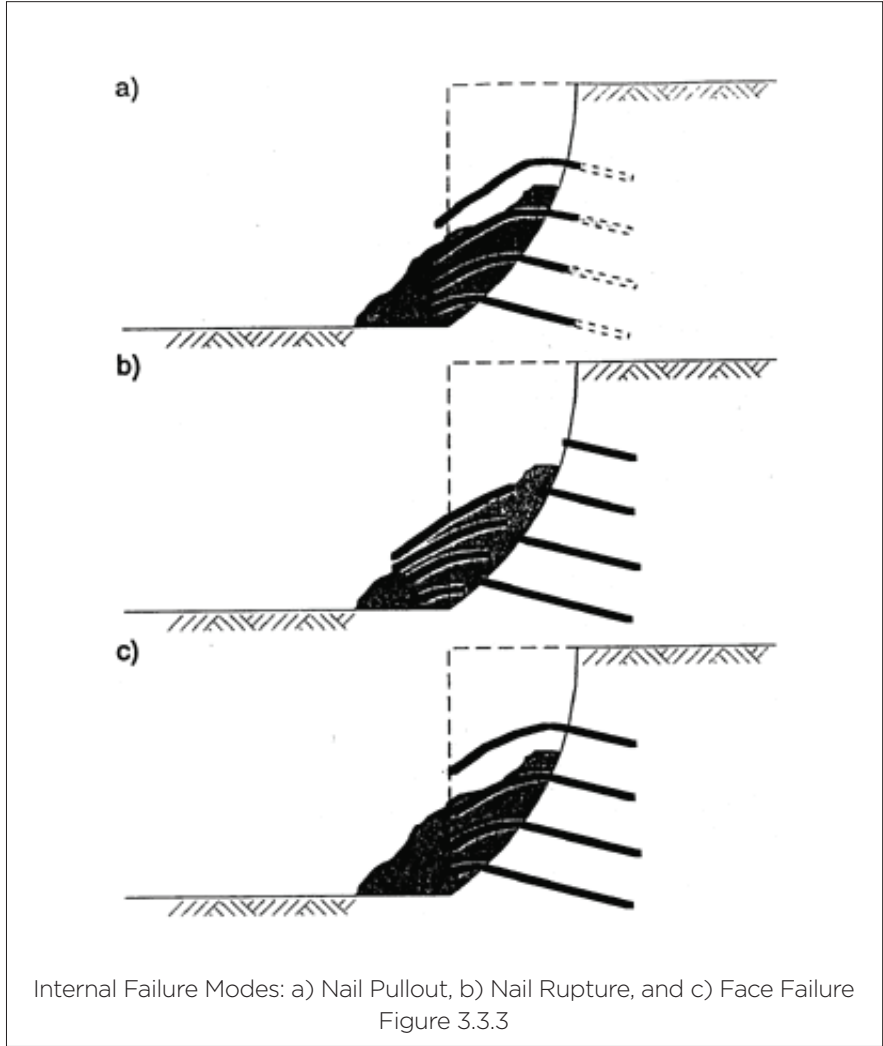

EXTERNAL STABILITY

Earth Pressures for External Stability

Stability computations for soil nail walls with a vertical face are made by assuming that the reinforced soil mass acts as a rigid body with earth pressures developed on a vertical pressure plane arising from the back end of the nails, as shown in Figures 3.4.1, 3.4.2 and 3.4.3.

The coefficient of active earth pressure is calculated for vertical walls and a horizontal back slope using Rankine earth pressure theory and is determined from the following equation:

$$K_a = \tan^2 (45 - \phi/2)$$

Equation 3-1

The coefficient of active earth pressure for a vertical soil nail wall with a continuous slope above the top of the wall (Figure 3.4.2) is determined using the following equation:

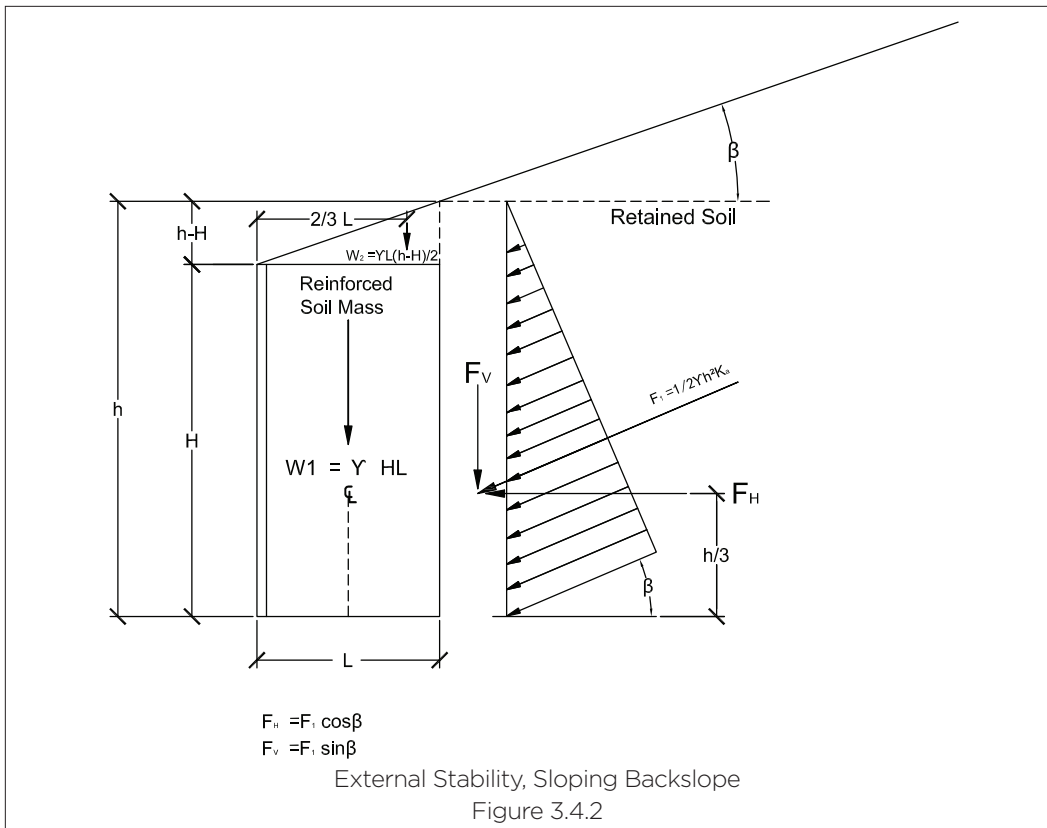
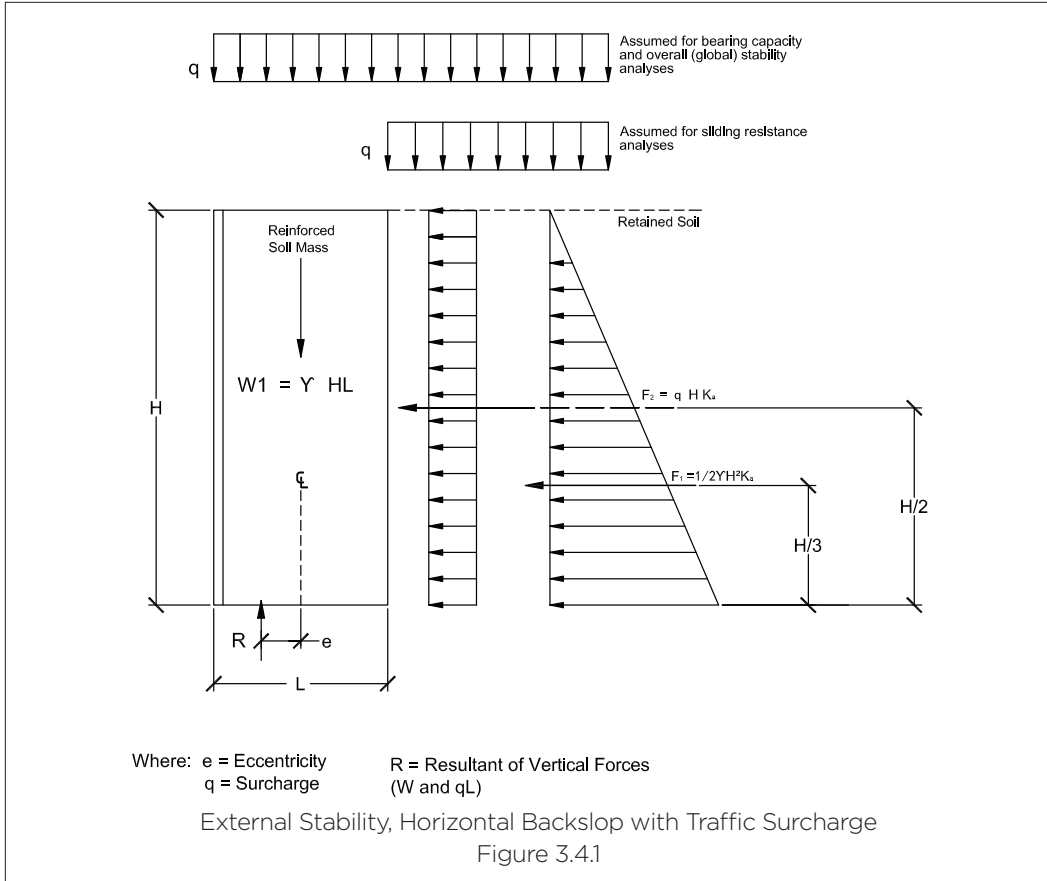

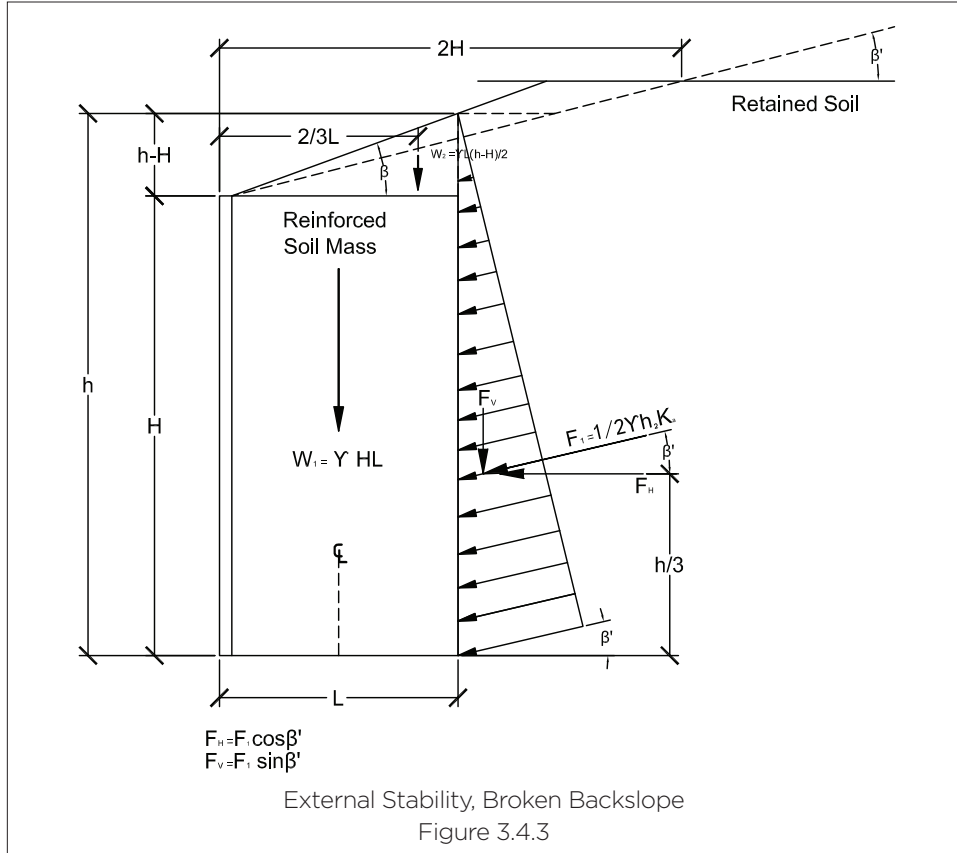

$$K_a = \cos\beta \frac{[\cos\beta - (\cos^2\beta - \cos^2\phi)^{1/2}]}{[\cos\beta + (\cos^2\beta - \cos^2\phi)^{1/2}]}$$

Equation 3-2

where: β = angle of slope above the top of the wall

For broken back slope conditions, the angle β' (Figure 3.4.3) is substituted for the infinite slope angle β . The angle β' is determined by constructing an effective infinite slope line that initiates from the top of the soil nail wall and intersects the ground surface above the wall at a distance of $2H$ from the wall face.

For an inclined front face, the coefficient of active earth pressure can be calculated from the general Coulomb Equation:

$$K_a = \frac{\sin^2(\theta + \phi)}{\sin^2\theta \sin(\theta - \delta) \left[1 + \sqrt{\frac{\sin(\phi + \delta) \sin(\phi - \beta)}{\sin(\theta - \delta) \sin(\theta + \beta)}} \right]^2}$$

Equation 3-3

where:

θ = wall face batter measured from vertical

β = the angle of the slope above the top of the wall measured from horizontal

δ = the wall friction angle assumed to be equal to zero

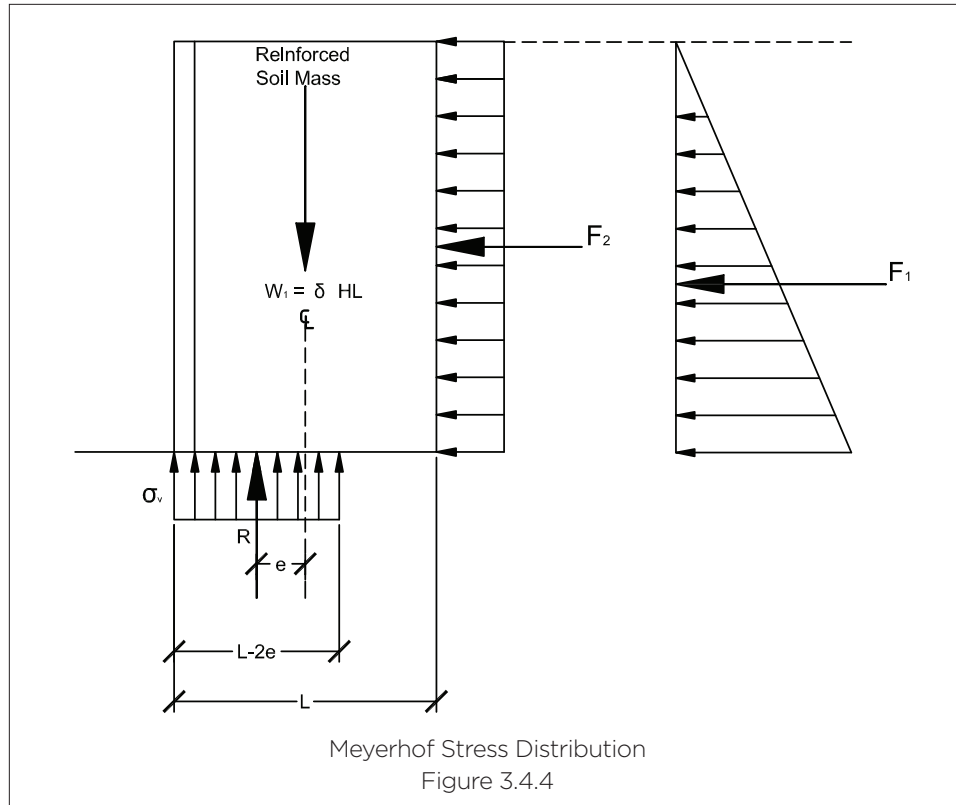

Sliding Stability

To determine the preliminary length of the soil nails, a check of the reinforced soil mass' resistance to sliding at the base of the soil nail wall should be performed. The factor of safety against sliding is determined as follows:

$$FS_{\text{sliding}} = \frac{\sum \text{Horizontal Resisting Forces}}{\sum \text{Horizontal Driving Forces}}$$

Equation 3-4

where the resisting force is the lesser of the shear resistance along the base of the wall, or of a weak layer near the base of the soil nail wall and the driving force is the horizontal component of the thrust on the vertical plane at the back of the nails (Figures 3.4.1, 3.4.2 and 3.4.3.).

The calculation steps for a SOIL SCREW® Retention Wall System with a level surcharge (Figure 3.4.1) are:

- 1) Calculate the lateral earth force F_1 :

$$F_1 = 1/2 K_a \gamma H^2$$

Equation 3.5

- 2) Calculate the horizontal surcharge force F_2 :

$$F_2 = K_a q H$$

Equation 3.6

- 3) Determine the resistance to sliding at the base of the wall:

$$R_{\text{sliding}} = W_1 \tan \phi$$

Equation 3.7

where: $W_1 = \gamma H L$

ϕ = the friction angle of the foundation soil

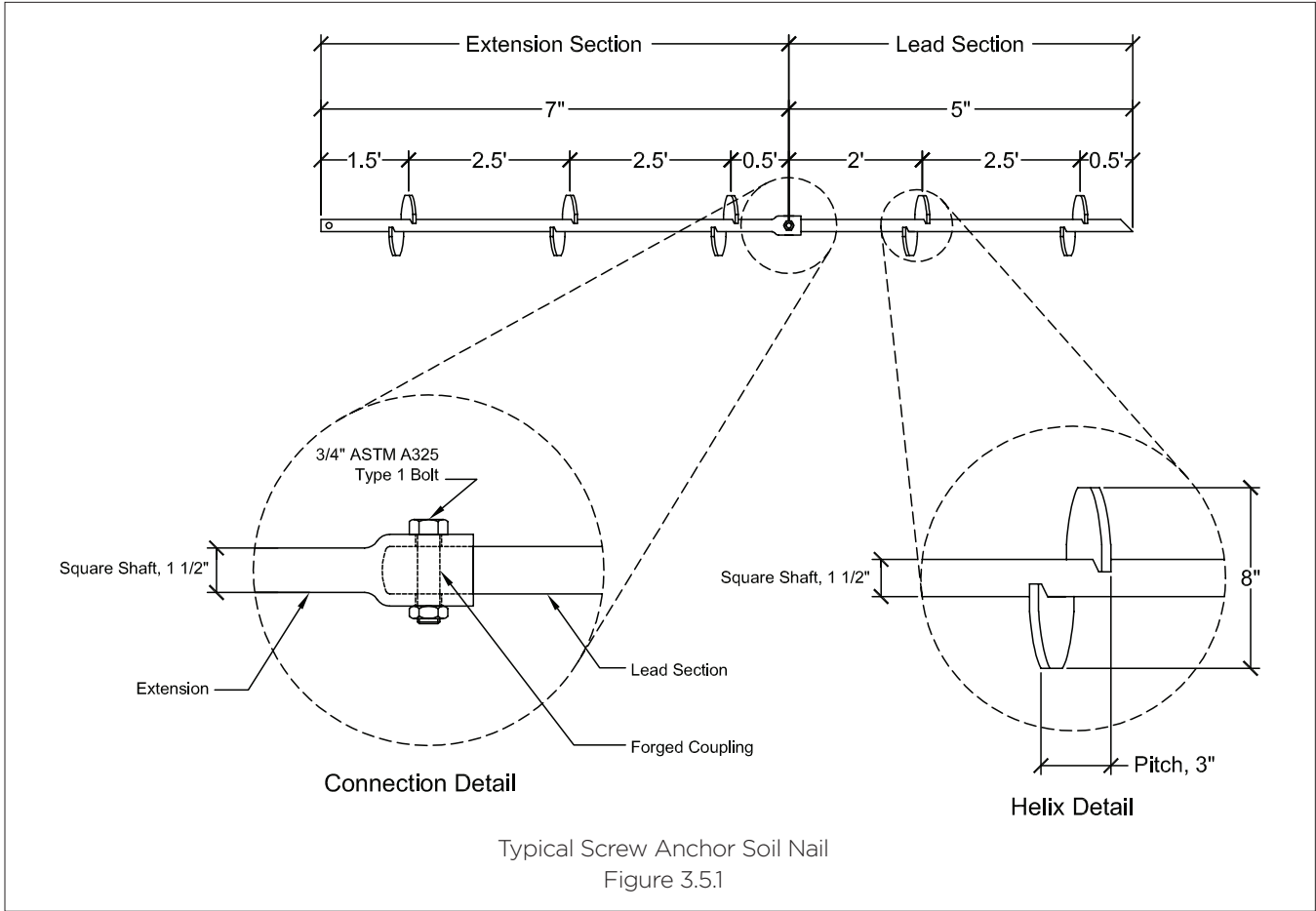

The factor of safety against sliding should be greater than or equal to 1.5. The required nail length for sliding is determined as follows:

$$L = \frac{1.5 (F_1 + F_2)}{\gamma H \tan \phi} \tag{Equation 3-8}$$

Bearing Capacity

A rule of thumb that has been developed for grouted soil nail walls and is likely to work equally well for walls using screw anchors is that the nail length should be from 0.5 to 0.8 times the wall height for a vertical wall and horizontal ground surface. The required bearing capacity for a soil nail wall must be determined and checked with respect to the allowable bearing capacity. The stress distribution below a soil nail wall is assumed to be the same as for other types of reinforced soil walls (i.e., mechanically stabilized earth) and is modeled using a Meyerhof stress distribution. Figure 3.4.4 shows the classical Meyerhof stress distribution. The contact area at the bottom of the soil nail wall is reduced in the Meyerhof bearing capacity analysis to a width of $L - 2e$. e is determined by summing moments about the centroid of the reinforced soil mass. For a horizontal backslope the eccentricity is determined as follows:

$$e = \frac{F_1 (H/3) + F_2 (H/2)}{W_1}$$

Equation 3-9

e must be less than L/6. If e is greater than this value, the length of the nail should be increased. The effect of the surcharge q would be to decrease e. Therefore, q is ignored for this calculation to be conservative. The vertical stress at the bottom of the soil nail wall (for a horizontal backslope) is determined as follows:

$$\sigma_v = \frac{W_1 + qL}{L - 2e}$$

Equation 3-10

The required bearing capacity is determined using classical soil mechanics. The factor of safety for bearing capacity for these relatively flexible reinforced soil walls is typically 2. The factor of safety for bearing capacity is defined as the ultimate bearing capacity (q_{ult}) divided by the required bearing capacity (σ_v).

$$FS_{\text{bearing}} = \frac{q_{\text{ult}}}{\sigma_v}$$

Equation 3-11

INTERNAL STABILITY

The ability of the soil nail wall to act as a coherent gravity mass is a function of the vertical and horizontal spacing of the nails, the long-term allowable strength of the nails, the stress transfer between the reinforced soil and the nail, the connection strength between the nail and the facing, and the flexural strength of the facing. These parameters and how they are determined are covered in the following sections.

Allowable Nail Strength

The allowable nail strength is a function of the service life of the structure, the grade of steel, the minimum cross sectional area of the nail, and the strength of the connection between the lead section, and extension pieces of the screw anchor.

Figure 3.5.1 shows the typical dimensions of a CHANCE® “SS” type anchor. The allowable tensile force in the screw anchor is determined by multiplying the cross-sectional area of the reinforcement at the end of the service life (considering corrosion of the steel) by the allowable tensile stress of the steel. The allowable tensile force in the screw anchors, T_a, is obtained as follows:

$$T_a = A_c (RF) F_y$$

Equation 3-12

where:

A_c = the design cross-sectional area of the steel (defined as the original cross-sectional area minus corrosion losses anticipated during the design life of the wall.)

F_y = the yield stress of the steel.

RF = the global reduction factor applied to the strength of the nail to account for uncertainties in structure geometry, soil properties, external applied loads, the potential for local overstress due to load non-uniformities, and uncertainties in the long-term nail strength, and is typically taken as 0.65.

Corrosion of anchors is a major consideration in permanent reinforced soil structures. For permanent applications, it is therefore, recommended that galvanized anchors be used to reduce the effects of corrosion on the anchor. The Federal Highway Administration (FHWA-SA-96-072) has established, from an extensive series of field tests on metal pipes and sheet steel buried by the National Bureau of Standards, maximum design corrosion rates for buried steel in soils exhibiting the electrochemical index properties listed in Table 3.5.1.

Recommended Electrochemical Properties for Soils when using the CHANCE SOIL SCREW® Retention Wall System, Table 3.5.1

Property	Criteria	Test Method
Resistivity	>3000 ohm-cm	AASHTO T-288-91
pH	>5<10	AASHTO T-289-91
Chlorides	100 PPM	AASHTO T-291-91
Sulfates	200 PPM	AASHTO T-290-91
Organic Content	1% max.	AASHTO T-267-86

The corrosion rates presented below are suitable for designs for screw anchors. These rates of corrosion assume a mildly corrosive in-situ soil environment having the electrochemical property limits that are listed above. The design corrosion rates, per FHWA-SA-96-072, are:

For Zinc

15 µm/year (first 2 years)

4 µm/year (thereafter)

For Carbon Steel

12µm/year (thereafter)

The strength of the coupling that connects sections of the anchor together must also be determined (Figure 3.5.1). Double shear of the bolt that connects the sections of the anchor together, controls the connection strength. CHANCE® SS5 anchors use A320 Grade L7 bolts. The design shear strength (V) of the bolt in double shear is determined as follows:

$$V = 2 A_b (RF) F_v$$

Equation 3-13

where:

A_b = the cross-sectional area of the bolt at the end of the service life of the nail (considering corrosion).

F_v = ultimate shear stress of the steel

RF = the global reduction factor applied to the strength of the nail to account for uncertainties in structure geometry, soil properties, external applied loads, the potential for local overstress due to load non-uniformities, and uncertainties in the long-term nail strength, and is typically taken as 0.65.

The allowable strength of the soil nail is the lesser of T_a and V . Table 3.5.2 lists the allowable strength of the galvanized SS5 screw anchor for a design life of 75 years, in a soil environment that meets the electrochemical properties listed in table 3.5.1.

Allowable Design Strength of CHANCE® SS5 Screw Anchor for a Service Life of 75 Years, Table 3.5.2

T_a 75 yrs (kips)	V 75 yrs (kips)	Allowable Design Strength (Temporary Structures) (kips)	Allowable Design Strength (75 years) (kips)
50	35	47	35

Pullout Capacity of Nail

Extensive laboratory and field research has been conducted to evaluate the pullout capacity of screw anchors (Yilmaz and Hanna (1971), Meyerhof (1973), Hoshiya and Mandal (1984), Das (1985), Mitsch and Clemence (1985), Mooney, et al (1985), Rapoport and Young (1985), Stewart (1985), and Hoyt and Clemence (1989). This research has taken the form of small-scale model testing and large-scale field pullout tests. Several proposed analytical models have been developed to estimate the pullout capacity of screw anchors. The method of estimating the pullout capacity of an anchor presented in this manual is as presented in Clemence, Crouch and Stephenson (1994). This approach was selected for two reasons; 1) the results predict, for the cases tested, the actual field results very closely; 2) the analytical approach is relatively straightforward and easy to apply.

The typical configuration of the screw anchors recommended for soil nailing applications is shown in Figure 3.5.1. The center-to-center spacing of the helices along the length of the anchor is nominally 2.5 feet. All helices are 8 inches in diameter.

Pullout of Screw Anchors in Sands and Silts

The observed failure mode from both field and laboratory pullout tests of screw anchors in sand when the helices are spaced a minimum of three (3) helix diameters apart, as is the case for CHANCE® SS5 Anchors, is individual helix bearing capacity.

The pullout capacity of a screw anchor is a function of the friction angle of the soil the anchor is embedded in, the number of helices behind the critical slip surface, and the effective overburden stress (Figure 3.5.2). The pullout capacity, P, is given by the following equation:

$$P = \sum_{i=1}^n A_i q_i N_{qi}$$

Equation 3-14

where:

P = ultimate pullout capacity

A_i = area of helix i

q_i = effective overburden pressure at helix i

$q_i = \gamma' z_i$

γ' = effective unit weight of the soil

z_i = depth from the ground surface to helix i

N_{qi} = the bearing capacity factor at helix i (Figure 3.5.3)

n = number of helices

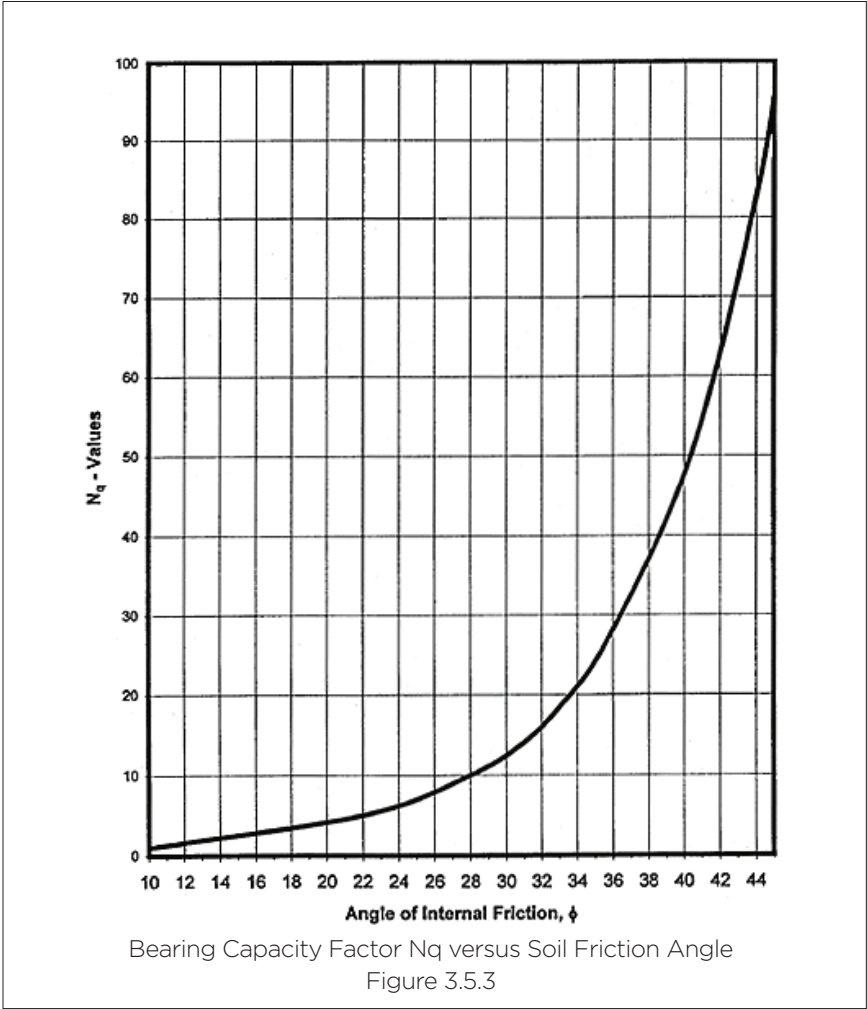
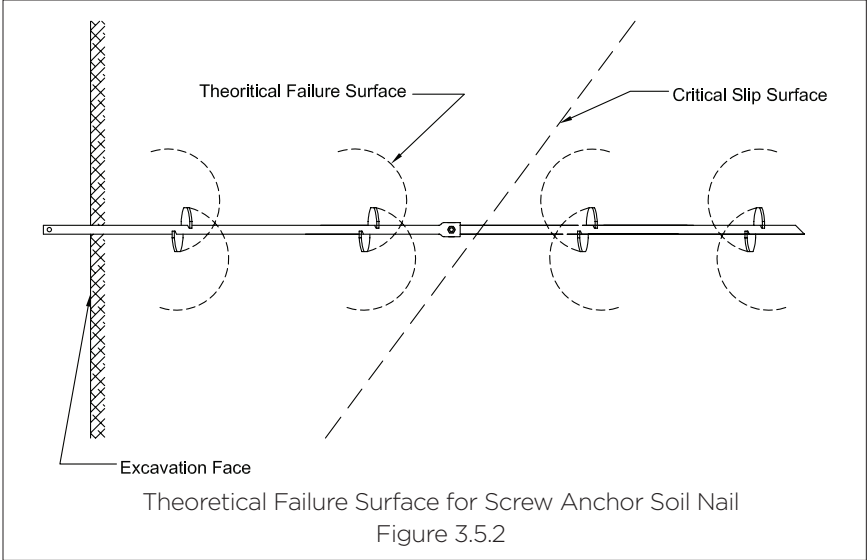

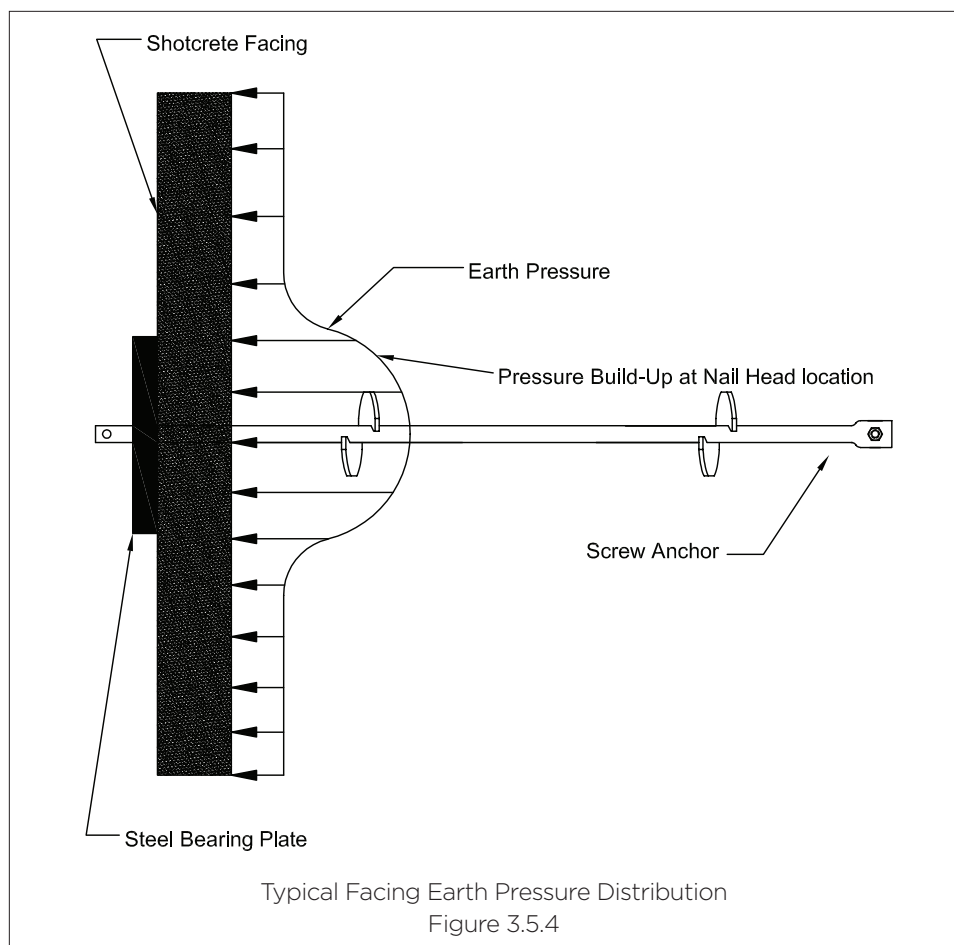

Facing Design

The facing of a soil nail wall has several functions: it provides lateral confinement of the soil at the face of the excavation; it prevents or minimizes the deterioration of the soil's shear strength associated with exposure to the elements; and it may support external loads (e.g. facing panels used for decorative purposes). The primary function of the facing is to prevent sloughing between nails. The spacing of the nails has a large influence on the design requirements for the facing. If, for example, the nails were spaced very close together, a facing would not be required.

The distribution of earth pressure on the facing between nails also affects the facing design. The earth pressure distribution on the face of a soil nail wall is non-uniform, (Figure 3.5.4) and is a function of the stiffness of the facing and distance between nails. Soil arching develops both vertically and horizontally between nails, resulting in stress concentrations around the nail face connection.

The design of the facing system (facing and the connection between the facing and the nail) must consider flexural failure of the facing between nails, and punching shear failure of the facing at the connection between the nail and facing. Flexure of the connection bearing plate and shear of the connection bearing plate are typically not analyzed in the design, if the bearing plate meets the following minimum criteria (FHWA-SA-96-069):

Bearing Plate:

- Minimum Yield Stress 36 ksi

- Minimum Plate Width 8 inches

- Minimum Plate Thickness 0.75 inches

If, however, the plate's strength, width or thickness is less than the values listed above, calculations should be performed to verify the adequacy of the connection plate.

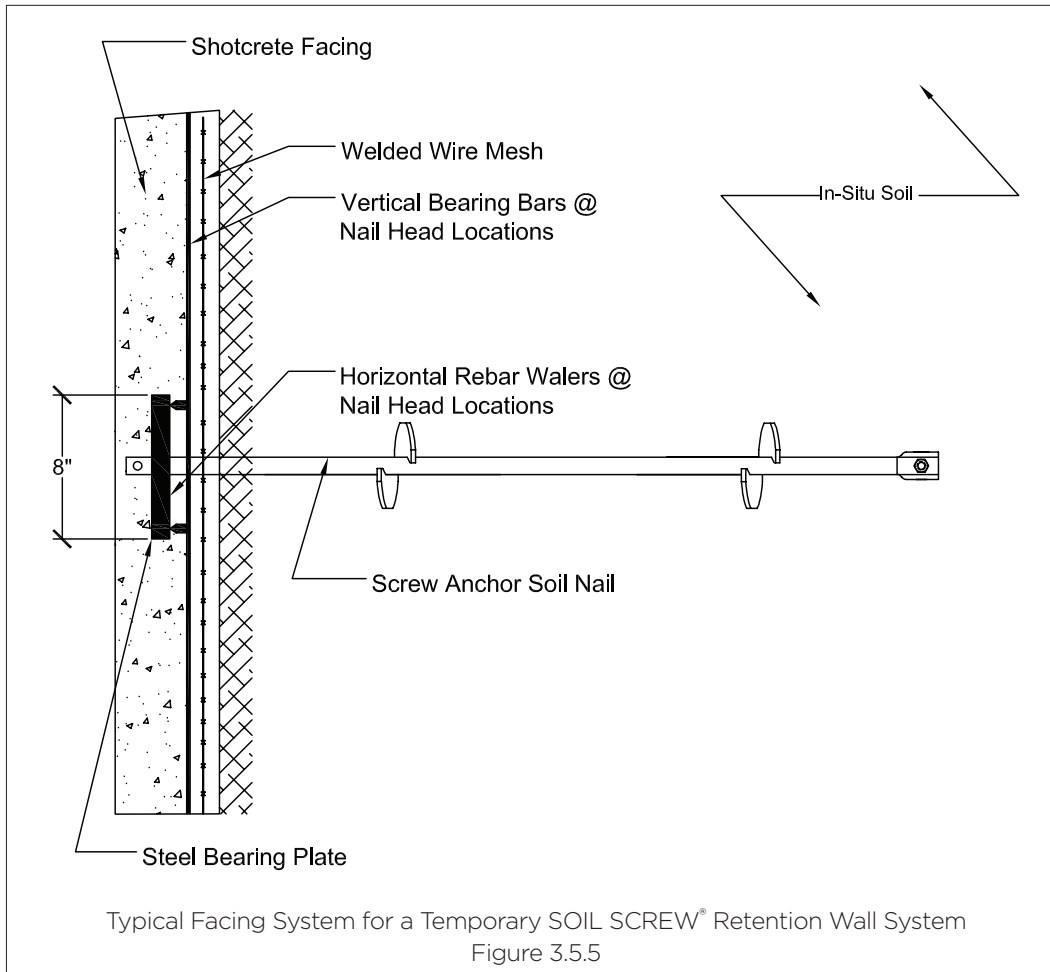

Flexural Strength of the Facing

The flexural strength of the proposed facing system for a soil nail wall must be analyzed to assure that the loads generated by the non-uniform earth pressure between the nails can be resisted without flexural failure of the facing. A typical facing system is shown in Figure 3.5.5. Horizontal and vertical reinforcing steel is added to the facing at each nail location. The design of the facing is based on a beam spanning vertically from nail to nail. The structural capacity of the facing can, therefore, be determined using standard reinforced concrete design procedures for singly-reinforced, rectangular concrete beams. The maximum moment that a unit width of the facing can withstand is determined as follows:

$$m_v \text{ (neg, pos)} = \frac{A_s F_y (d - A_s F_y / 1.7f'_c b)}{b} \quad \text{Equation 3-15}$$

where:

- A_s = the area of vertical steel over the nails (negative moment) and at the midspan (positive moment)
- F_y = yield strength of the reinforcing steel
- b = width of the beam (horizontal spacing between nails)
- d = distance from the extreme face of the shotcrete to the centroid of the reinforcement
- f'_c = compressive strength of the concrete

Once the maximum allowable moment of the proposed facing system for a soil nail wall is determined, the maximum nail head load (critical nominal nail head strength associated with flexural failure of the facing, $T_{FNflexure}$) that the facing can carry is evaluated. $T_{FNflexure}$ can be determined as follows:

$$T_{FNflexure} = C_F (m_{v,neg} + m_{v,pos}) 8S_H/S_V \quad \text{Equation 3-16}$$

where:

S_H = horizontal nail spacing

S_V = vertical nail spacing

C_F = is a dimensionless factor to account for facing flexibility.

C_F may be estimated using Table 3.5.3. The values listed in this table are based on back analysis of instrumented case histories, calibrated full-scale laboratory tests, calibrated finite-element modeling, experience and judgment. For additional information concerning the development of equation 3.16 or C_F , see FHWA 1996 Synthesis Report on Soil Nail Wall Facing Design.

The above equations have been developed for the typical soil nail project, where the vertical nail spacing is greater than the horizontal nail spacing. If this is not the case, then the facing should be analyzed with respect to the moments in the horizontal direction.

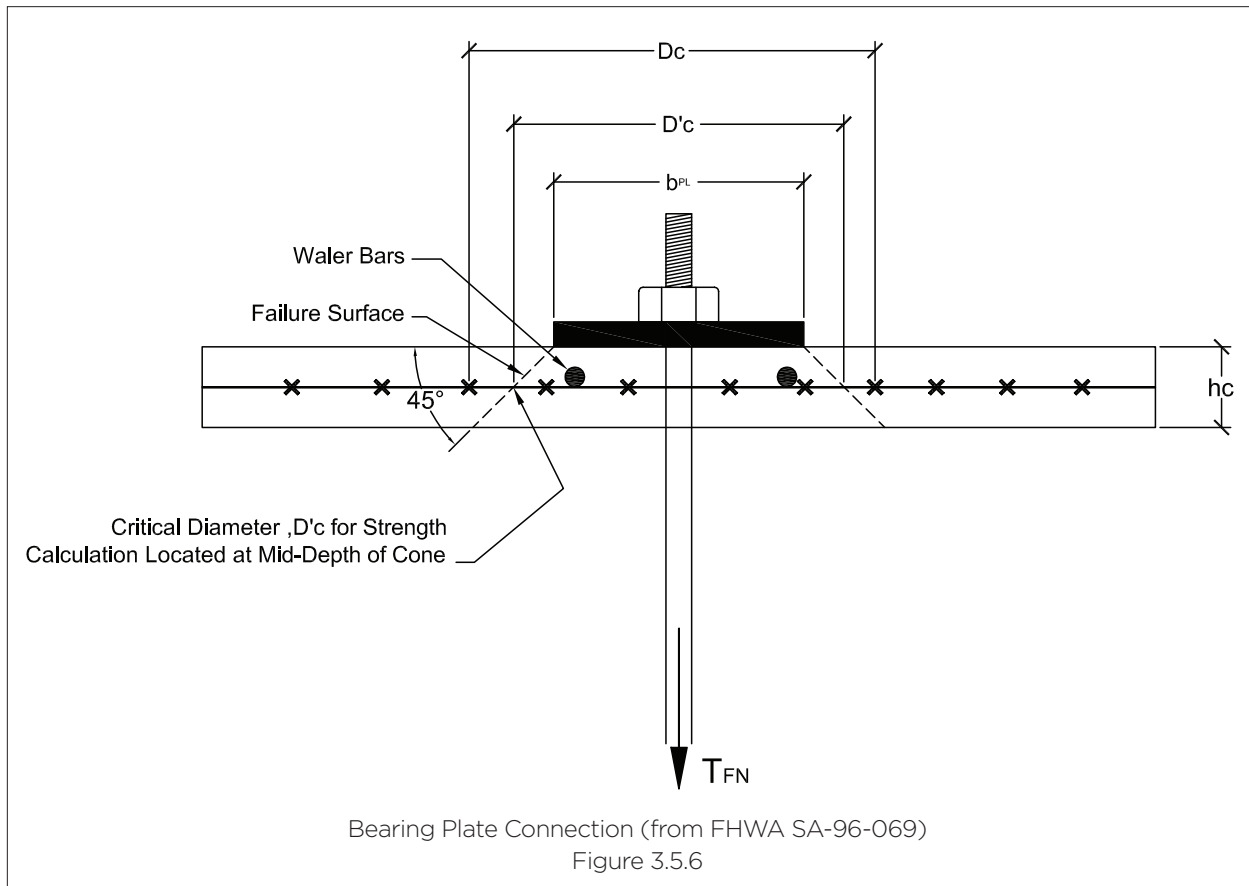

Facing Pressure Factor (FHWA Synthesis Report), Table 3.5.3

Nominal Facing Thickness (inches)	Temporary Facing	Permanent Facing
	C_F	C_F
4	2.0	1.0
6	1.5	1.0
8	1.0	1.0

DESIGN GUIDELINES

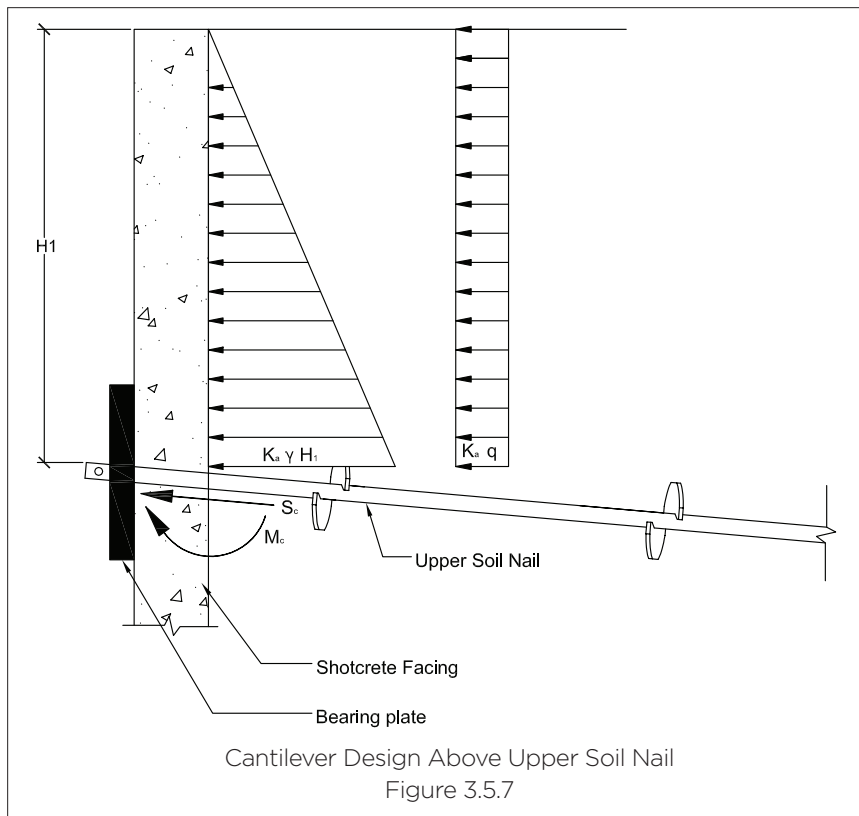

Punching Shear Strength of the Facing

The typical connection between the SOIL SCREW® Retention Wall System and the facing system for a soil nail wall is shown in Figure 3.5.5. For the design of connections using bearing plates with shear studs, see FHWA -SA-96-069 Manual for Design & Construction Monitoring of Soil Nail Walls.

Punching shear failure of the connection of a soil nail system, as presented in FHWA-SA-96-069, is shown in Figure 3.5.6, and involves punching a cone of shotcrete centered about the nail head through the facing. There are two components of the resistance of the system to punching shear; the resistance provided by the facing (shotcrete and reinforcing steel); and the resistance provided by the soil behind the facing. The analysis procedure presented herein ignores the contribution of the soil in determining the punching shear strength because the soil at the face of the wall is generally disturbed by the installation of the anchor and may provide little or no bearing resistance. It also assumes that the square bearing plate may be represented by a circular plate with a diameter equal to the width of the plate and that welded wire mesh steel reinforcement does not provide any shear capacity reinforcement.

With these simplifying assumptions, the punching shear strength of the facing system may be determined using standard reinforced concrete design procedures. The punching shear strength of the facing, V_N (in kips), is determined as follows:

$$V_N = 0.125 (f'_c)^{1/2} \pi D'_c h_c \quad \text{Equation 3-17}$$

where:

D'_c = the effective cone diameter (see Figure 3.5.6) at the center of the facing ($D'_c = b_{pl} + h_c$)

h_c = the thickness of the shotcrete facing

f'_c = compressive strength of shotcrete in ksi

Ignoring the resistance to punching shear provided by the soil, the critical nominal nail head strength associated with punching shear failure, $T_{FNpunching}$, is equal to V_N .

$$T_{FNpunching} = V_N \quad \text{Equation 3-18}$$

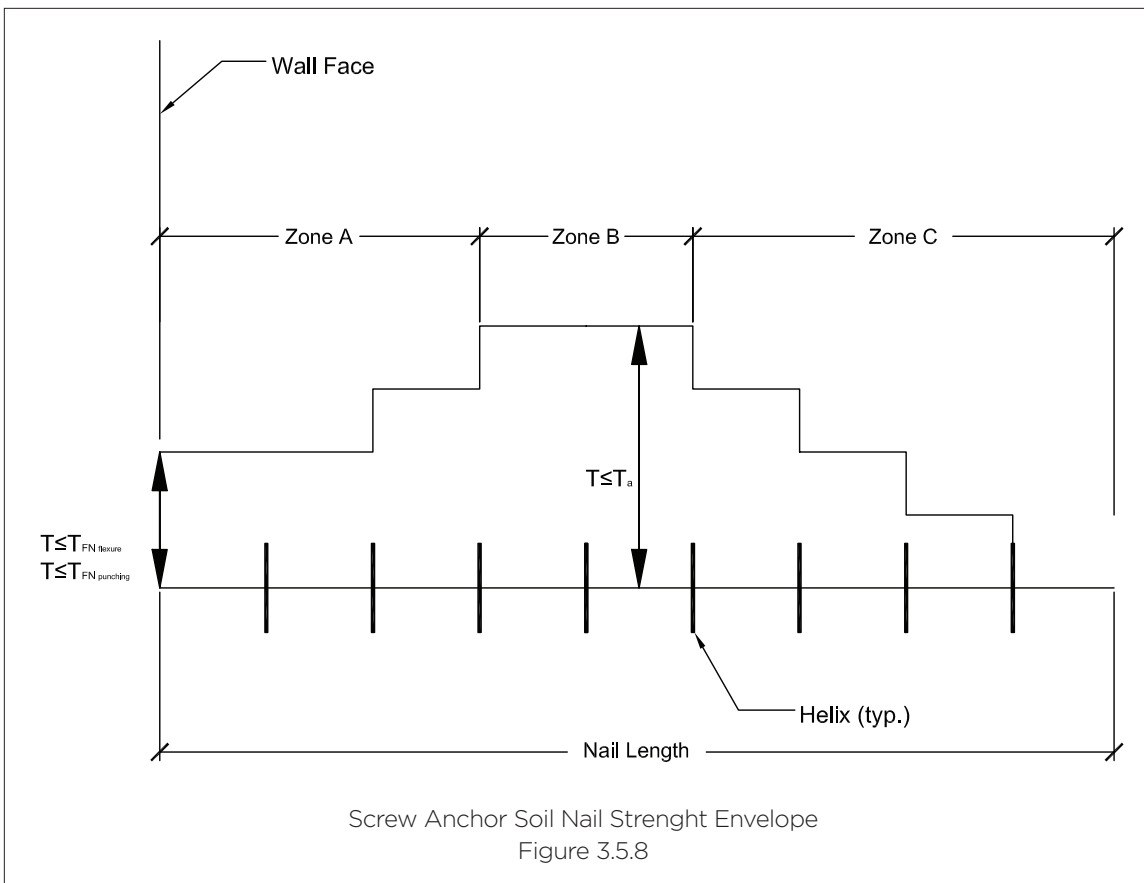

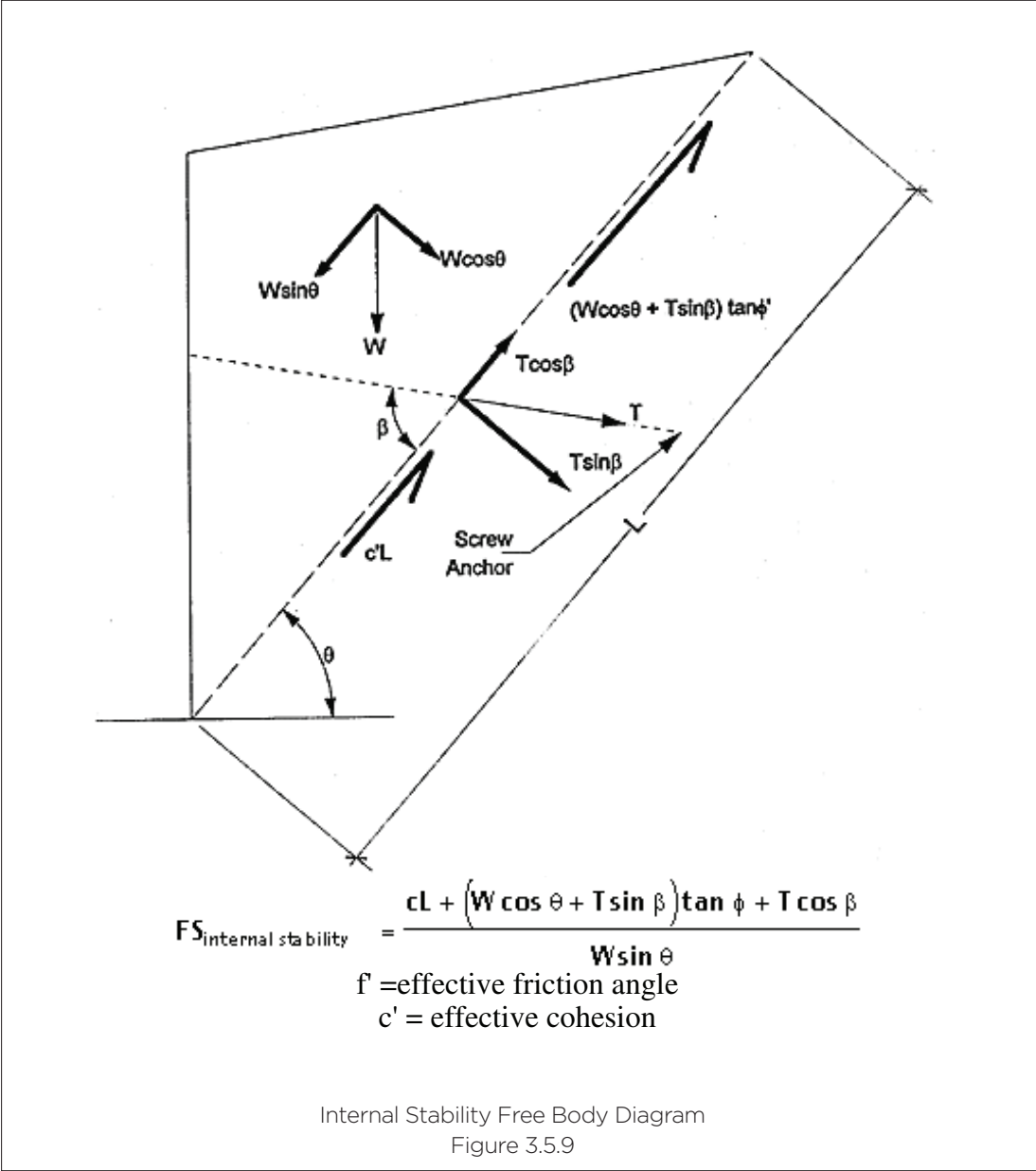

Cantilever Design Check

The cantilever at the top of a soil nail wall must be checked to assure that the facing has adequate moment and shear capacity to withstand the applied earth pressure that is developed as a result of the self weight of the soil and any surcharge load (Figure 3.5.7). The cantilever moment (M_c) that the wall must resist is determined as follows:

$$M_c = K_a \left[\gamma \left(\frac{H_1^2}{2} \right) \left(\frac{H_1}{3} \right) + q \frac{H_1^2}{2} \right] \tag{Equation 3-19}$$

The maximum cantilever moment that the facing can withstand is determined using equation 3.15 at the midspan between nails. The factor of safety for cantilever bending, FS_{M_c} , is defined as the maximum allowable moment divided by the required cantilever moment. FS_{M_c} should be equal to or greater than 1.5.

The shear force, S_c , that the cantilever section of the wall face must resist is determined as follows:

$$S_c = K_a [\gamma (H_1^2/2) + q H_1] \quad \text{Equation 3-20}$$

This shear force is resisted by the allowable shear strength of the facing at the top nail tier, which is determined as follows:

$$V_N = 0.125 (f'_c)^{1/2} h_c \quad \text{Equation 3-21}$$

The factor of safety against shear failure of the cantilever at the top of the wall should be greater than or equal to 1.5.

Nail Strength Envelope

The distribution of allowable load along the length of the nail can be determined once the allowable nail strength, pullout capacity, nail head flexural capacity, and nail head punching shear capacity have been determined. Figure 3.5.8 shows the theoretical distribution of nail strength along the length of the nail. At the face of the wall, the nail strength is governed by the flexural and punching shear strength of the facing system and is the lesser of $T_{FNflexure}$ and $T_{FNpunching}$. In zone A, the nail strength increases until either the pullout strength or allowable strength is reached. If the length of the nail is long enough to develop the allowable strength of the nail (i.e., the pullout capacity of the nail exceeds the allowable strength), then zone B develops. Zone C is the termination zone of the nail, where the strength of the nail decreases, stepwise at each helix, to zero.

Internal Stability Limit Equilibrium Analysis

The ability of the reinforced soil mass to behave as a coherent gravity structure must be analyzed. Figure 3.3.3 shows the internal stability failure modes. Traditional slope stability analysis techniques are utilized to evaluate the internal stability of a soil nail wall.

The inclusion of the screw anchors increases the stability of the reinforced soil mass by increasing the normal force on the failure surface, which intersects the anchors, resulting in an increase in shear strength of frictional soils, and increasing the resisting forces. Figure 3.5.9 shows a free body diagram for the internal stability of a soil nail wall, with the multiple nails idealized as one nail, for a wedge-shaped failure surface. The factor of safety with respect to internal stability is determined as follows:

$$FS_{\text{internal stability}} = \frac{cL + (W \cos \theta + T \sin \beta) \tan \phi + T \cos \beta}{W \sin \theta} \quad \text{Equation 3-22}$$

where:

c = cohesion

L = the length of the failure surface

W = weight of the soil wedge

θ = the angle from horizontal of the failure surface

β = the angle of the screw anchor from horizontal

ϕ = the friction angle of the soil

T = the tensile force provided by the screw anchor

The contribution of any anchor to the stability of the reinforced soil mass is a function of the tensile strength of the anchor; the pullout resistance of the anchor beyond the failure surface; or the anchor head strength and the pullout resistance of the length of the anchor between the slip surface and the face of the wall (Figure 3.5.8).

There are several commercially available soil nailing computer programs that have been developed specifically to determine the stability of soil nail walls (i.e., SNAIL and GOLDNAIL). In addition to these programs, commercially available slope stability programs may also be modified to perform this analysis.

GLOBAL STABILITY

The global stability of all soil nail structures should be evaluated. Figure 3.3.2 shows a global stability failure surface. The typical factor of safety for global stability is 1.3. Limit equilibrium analysis, as with internal stability analysis, is used to check global stability.

SUMMARIZED DESIGN STEPS

Feasibility Assessment

1. Define design parameters (i.e., soil properties, design geometry, loading conditions, etc.).
2. Check preliminary feasibility of soil nailing. Are the site conditions favorable for the SOIL SCREW® Retention Wall System (section 3.2.)?
3. Using design charts, (section 3.2.3), select a preliminary anchor length (L) and vertical and horizontal spacing of the nails (SV & SH).

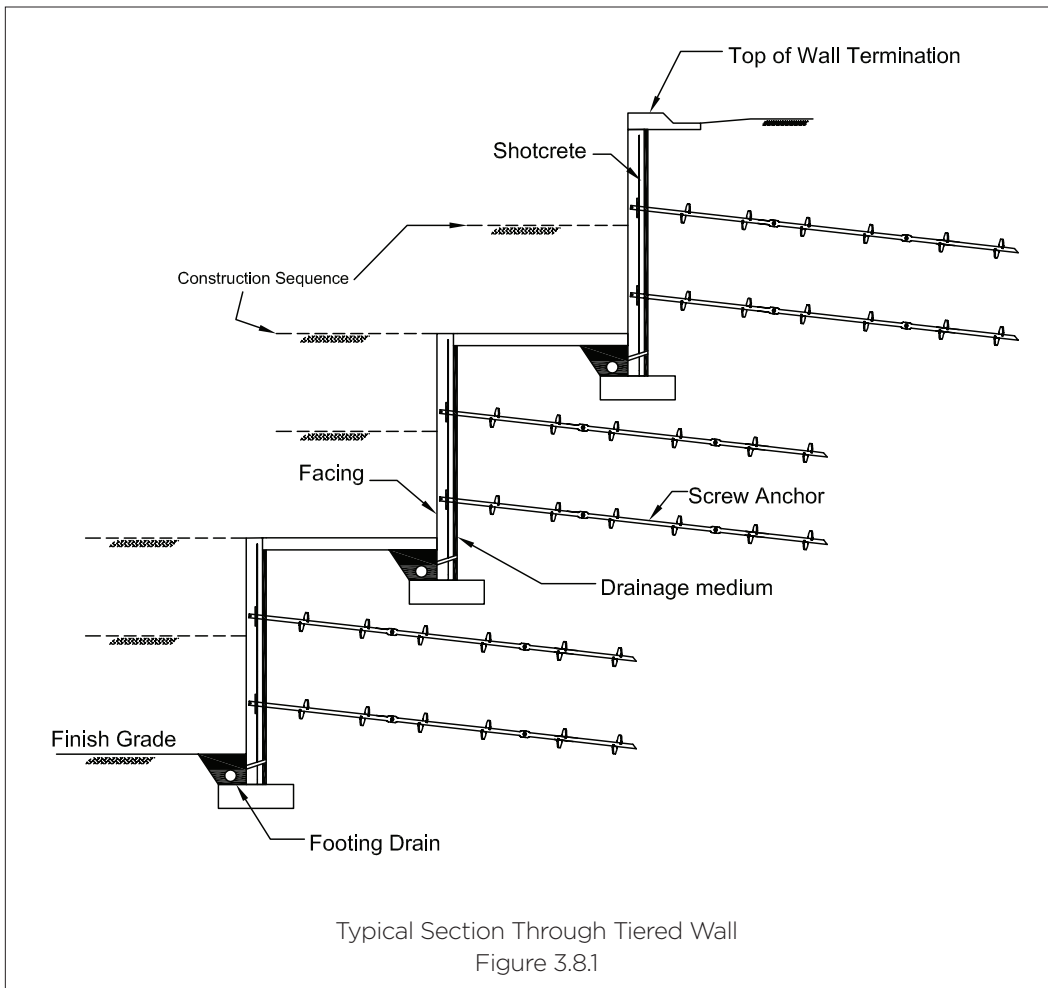

External Stability

4. Determine the external earth pressure that the wall will be required to resist (equations 3.1 through 3.3).
5. Check the preliminary anchor length with respect to sliding of the soil anchor structure (equation 3.8). If the required anchor length for sliding stability is greater than the estimated length based on the feasibility analysis, increase L .
6. Check the required bearing capacity of the soil nail structure to assure adequate foundation performance using equations 3.9 through 3.11.

Internal Stability

7. Determine the allowable strength of the anchors using equations 3.12 and 3.13. For permanent structures, include the effects of corrosion in determining the allowable strength of the anchor.
8. Estimate the pullout capacity of the anchor using equation 3.14.
9. Select a preliminary facing system (i.e., shotcrete thickness, shotcrete compressive strength, steel reinforcement, bearing plate, etc.).
10. Determine the allowable flexural strength of the facing system, selected in step 8, using equation 3.15.
11. Determine the maximum nail head load that will produce the allowable moments determined in step 9.
12. Determine the allowable punching shear strength of the facing system at the connection with the nail using equation 3.17.
13. Determine the critical nail load strength associated with the allowable punching shear strength of the facing.
14. Construct the nail strength envelope from the parameters determined in steps 7-13 ($T_{FNflexure}$, $T_{FNpunching}$, T_a , and P).
15. Using the nail strength envelope, perform limit equilibrium stability analysis to determine the internal stability (including compound failure) of the soil nail wall.
16. Check global stability of the soil nail system using a limit equilibrium slope stability program.
17. Check the cantilever at the top of the wall to assure adequate shear and flexural capacity using equations 3.19 - 3.21.
18. Prepare specifications and construction drawings.

SPECIAL DESIGN CONSIDERATIONS

Tiered Walls

Tiered walls, walls with a stepped or benched facing (Figure 3.8.1.), may be used on a project for aesthetic reasons. The setback areas are often used for planting vegetation. Where the horizontal setbacks are less than 0.35 times the height of the tier, the structure will tend to act as a single equivalent wall with a battered face. For walls with larger steps, the walls should be designed individually, with a surcharge load equivalent to the tiers above the top of the individual wall being designed. A check of the global stability of the total system is critical in the design of a tiered soil nail structure, to assure that the length of the nails is long enough to provide stability for the full height of the wall, including all tiers.

Surcharge Loads

The surcharge loads that may be applied to a soil nail structure may range from relatively light (e.g., nominal live loads to account for traffic loads) to relatively heavy loads in relation to the weight of the retained soil (e.g., surcharge corresponding to an bridge abutment spread footing located on top of the soil nail wall). For surcharge loads that act over the reinforced soil (internal stability), the surcharge load should be included in the internal stability analysis. The minimum facing connection system requirement should be determined in accordance with section 3.5, taking into account the loads applied by both the self weight of the soil and the surcharge loads.

If the surcharge load continues behind the reinforced soil mass, its effect on external stability should also be considered. For large surcharge loads (e.g., footing loads) acting behind the reinforced soil mass, Figure 3.4.1 and 3.4.2 should be used to determine the effect of the surcharge on external stability of the structure.



DESIGN GUIDELINES



CONSTRUCTION - MATERIALS, INSTALLATION AND MONITORING SECTION 4

CONTENTS

MATERIALS.....	4-3
Screw Anchors.....	4-3
Wall Connectors.....	4-4
Shotcrete.....	4-5
Drainage Materials.....	4-6
ALTERNATE FACING MATERIALS.....	4-6
INSTALLATION EQUIPMENT.....	4-6
INSTALLATION, MONITORING AND TESTING.....	4-7
Installation.....	4-7
Monitoring and Testing.....	4-10

CONSTRUCTION

DISCLAIMER

The information in this manual is provided as a guide to assist you with your design and in writing your own specifications.

Installation conditions, including soil and structure conditions, vary widely from location to location and from point to point on a site.

Independent engineering analysis and consulting state and local building codes and authorities should be conducted prior to any installation to ascertain and verify compliance to relevant rules, regulations and requirements.

Hubbell Power Systems, Inc., shall not be responsible for, or liable to you and/or your customers for the adoption, revision, implementation, use or misuse of this information. Hubbell, Inc., takes great pride and has every confidence in its network of installing contractors and dealers.

Hubbell Power Systems, Inc., does NOT warrant the work of its dealers/installing contractors in the installation of CHANCE® Civil Construction foundation support products.

The materials for construction of a soil nail wall will vary with local practice and site conditions. The following section provides some guidelines on the materials for construction, how they can be installed, and how installation can be monitored.

MATERIALS

A plan view of a CHANCE SOIL SCREW® Retention Wall System with a permanent shotcrete facing is provided in Figure 4.1.1 and shows the components of the SOIL SCREW® Retention Wall System required to build the wall. Each of the components is discussed below.

Screw Anchors

SOIL SCREW® Retention Wall System anchor lead sections and extensions are manufactured in standard lengths of 5 feet and 7 feet. The lead section has a bolthole on the top and a pilot point on the bottom. The extension has a bolthole at the top and a socket with a bolthole on the bottom. Both lead sections and extensions have 8-inch diameter helices spaced on approximately 2.5-foot centers. Each installed anchor will consist of one lead section and may have one or more extensions as well.

If additional anchor length is required for making attachments to facing systems, this can be provided with short extensions without compromising the soil nail design. These extensions are shown on Figure 4.1.2 and include a 20-inch long threaded adapter, an 11-inch long threadbar adapter and several lengths of plain extension. These are all standard products used for both soil nails and tieback anchors.

Screw anchor leads and extensions come in either galvanized or black steel, depending upon the project requirements. Threaded adapters and thread bar adapters are all galvanized.

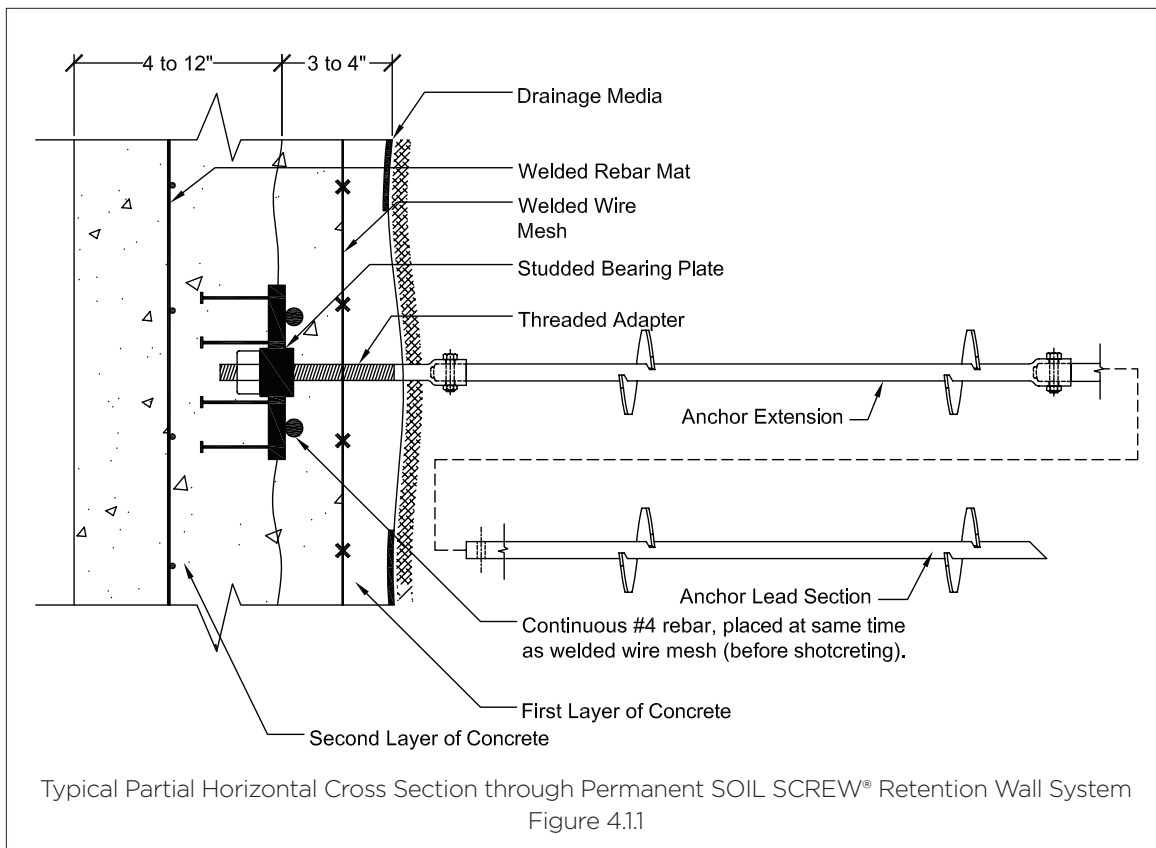

Typical spacing for screw anchor soil nails varies from a four-foot center-to-center pattern, to a 5 by 6 foot pattern, depending upon wall height and soil conditions.

Wall Connectors

Connection of the screw anchor to the shotcrete facing can be designed and constructed in several ways. The cost of the connector is a function of the performance desired and the design life. For temporary soil nail walls, the connection needs to be of sufficient durability to last until the end of the project. Stress transfer to the face occurs over an extended period of time in a soil nail wall, depending on the shear strength of the reinforced soil. Connectors utilizing a 3/4 inch thick plate and #4 rebar, as shown in Figure 4.1.3, are typically sufficient. The shotcrete thickness will vary from 3 to 4 inches and should completely cover the connector. For permanent walls, the ability to positively tension the connector is desired. The use of a threaded connector facilitates tensioning the anchor by torquing the nut, thus reducing the potential for localized movement

CONSTRUCTION

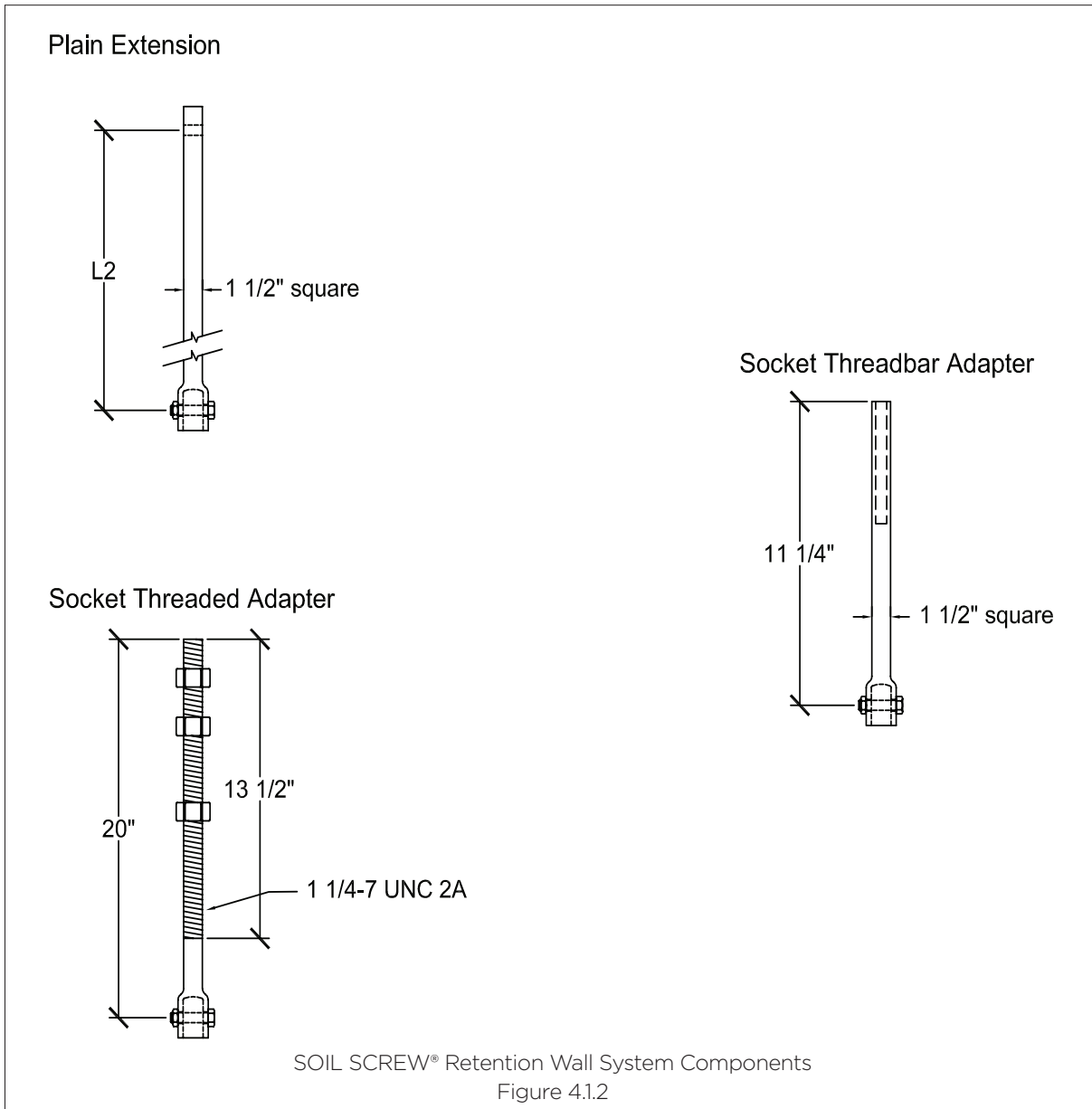

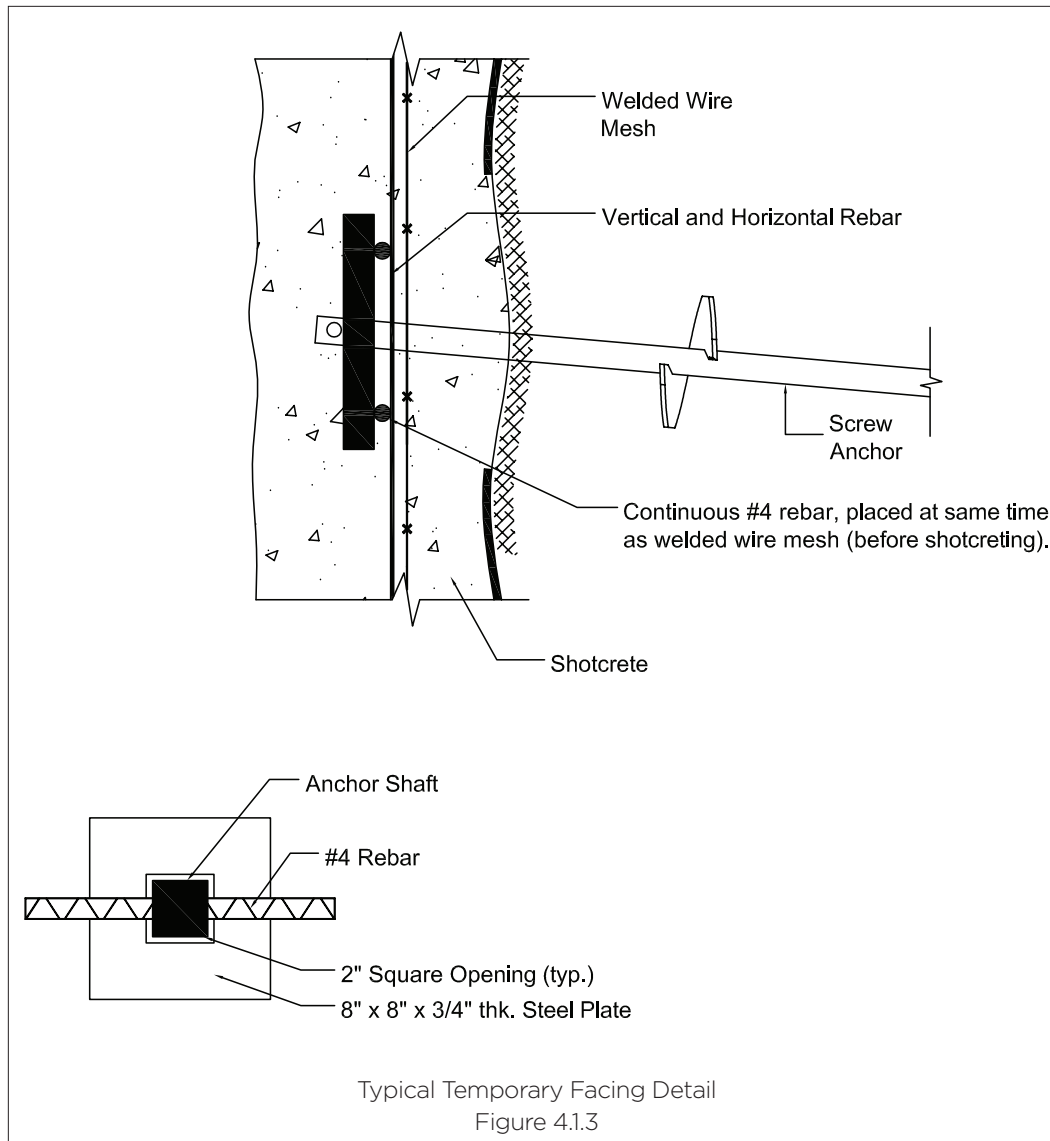

of the face. Figure 4.1.1 shows an example of a typical permanent connector using a threaded adapter that is bolted to the bearing plate. For this application, a bearing plate with studs is used for increased bond between the concrete face and nail head.

Shotcrete

The function of the shotcrete in a soil nail wall is to create a barrier to prevent deterioration of the excavated soil face and to provide a structural facing to transfer soil stress to the nail heads. Shotcrete is applied as soon after excavation and nail placement as possible. In some cases it may be applied immediately after excavation if poor ground is encountered. In this case, its function is to stabilize the excavation face so nails can be installed.

Shotcrete is defined as concrete or mortar that is projected at high velocity onto a surface. Shotcrete is comprised of cement, water and aggregate typically less than a 1/2 inch sieve size, with the majority of the aggregate classified as sand size particles. Wet-mix shotcrete is normally used since it is usually less expensive, easier to install and has a higher throughput. The properties of the shotcrete that are critical during installation

are its ability to be pumped and its adhesion. These are controlled by the mix design, cement water ratio, air entrainment, the pumping system used and other variables. A detailed discussion of shotcrete mix design and placement properties is provided in the FHWA-SA-96-069 Manual for Design and Construction Monitoring of Soil Nail Walls, November 1996.

The critical properties of finished shotcrete are its shear and flexural strength to prevent punching failure at the nail head and support the retained soil, and its bond with the steel reinforcements to transfer stress.

Wire mesh or rebar used with shotcrete should be spaced so the openings between bars are greater than 4 inches to be sure that bond is obtained with the soil face and around the reinforcing bars.

The required strength of the shotcrete will be determined as part of the design process. However, as a minimum to provide adequate strength and durability, the shotcrete will need to have a minimum 28-day compressive strength of 4000 psi, and a water/ cement ratio of less than 0.5.

Detailed specifications for shotcrete construction are provided in Appendix B.

Drainage Materials

Drainage behind the wall face is typically provided by placement of strip drains as shown in Figure 4.1.1. Strip drains are placed between the columns of nails, however, if localized seepage zones are encountered during construction, additional drains may be needed to help relieve pore pressure buildup. It is important to control water during construction to develop a good bond between the excavated soil and the shotcrete. However, adequate space for the soil/shotcrete bond is recommended, typically 50% or more, so that shotcrete does not delaminate, and voids are not created behind the wall face.

Strip drains should provide a continuous drainage path from the top of the wall to the bottom interceptor drain or weep hole. Normally, a single drain can be unrolled from the top down as excavation progresses. However, very special care must be taken during subsequent excavation to protect the strip drain from damage during excavation. If splicing of drains is required, care should be taken to make sure that the drain cores are all covered with a geotextile to prevent clogging. Drains should be spliced or “shingled” in a manner as recommended by the manufacturer to assure that water from the upper drain flows readily to the lower drain.

ALTERNATE FACING MATERIALS

As discussed in section 2.3, precast concrete panels, segmental retaining wall units and gabion or welded wire facings, can also be used for facings of soil nail walls. Each of these has specific attachment details essential to their performance and are best addressed on a project-by-project basis, and by the supplier of the relevant facing systems. Typical details from projects where some of these materials have been used are contained in Figures 2.3.1, 2.3.2 and 2.3.3.

Common to each of these facings will be the need to:

- Provide a connection that will control wall face movements and has adequate tensile strength for the anticipated design life.
- Provide containment for the soil exposed during excavation.
- Provide the flexural stiffness needed to support soil between the soil nails.
- Provide a system that is economic and easy to install.

INSTALLATION EQUIPMENT

Figure 4.3.1 shows some of the torque heads and drive tools that can be used to install the screw anchor soil nails. These tools can be used with most any construction equipment by coupling the torque head to the hydraulic unit of the equipment. The flow and pressure requirements of each torque head are provided in Figure 4.3.1. Typically, units require that the hydraulic system have a forward, neutral, and reverse setting to be able to back out anchors, if needed. A standard backhoe, trackhoe or even a skid loader, can be used for installation of the anchors.

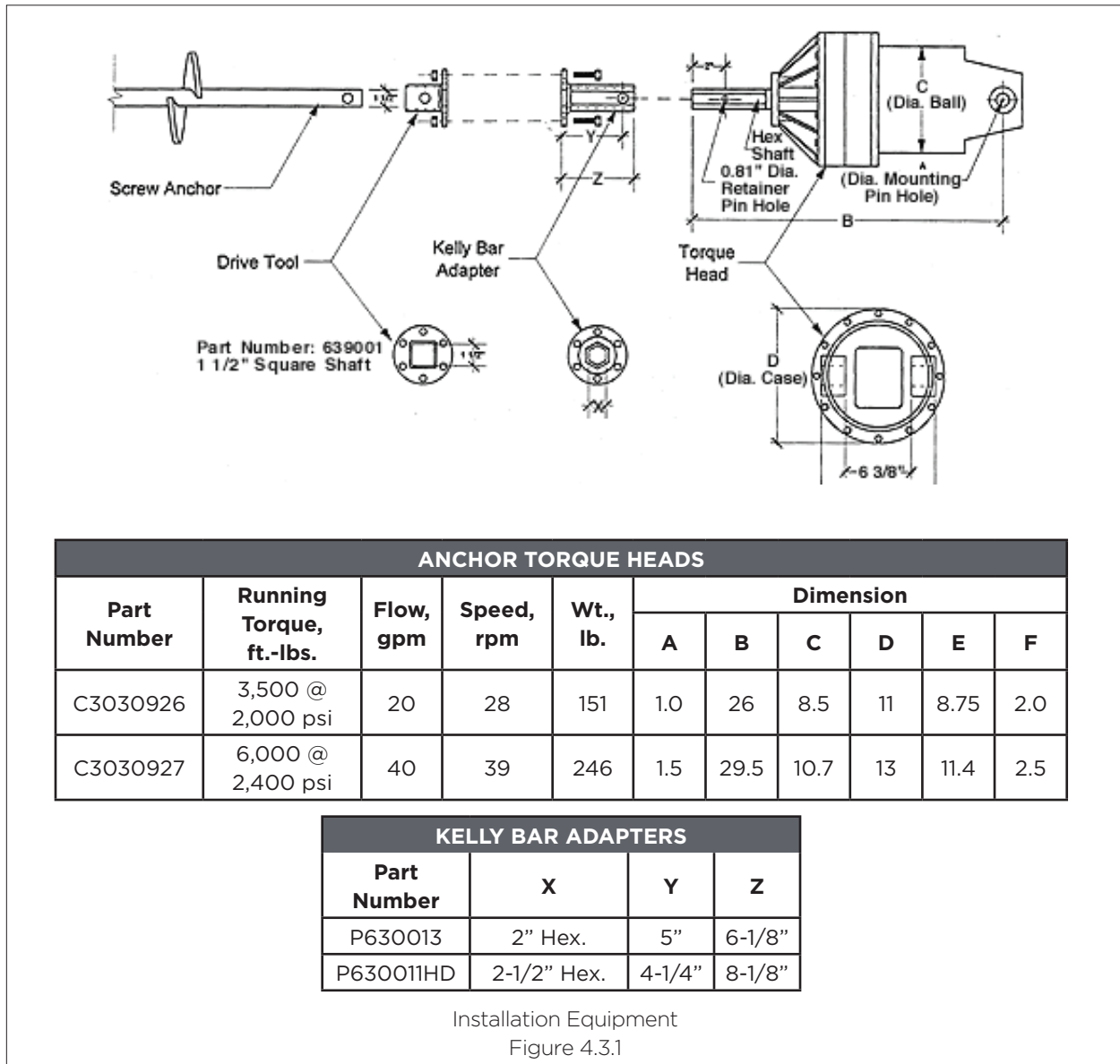

Screw anchors can also be installed with any drill rig that can provide the necessary torque. For these units, all that is needed are the Kelly bar adapter and drive tool shown in Figure 4.3.1. Installation rates of up to 50 anchors per day can be obtained using this type of equipment.

INSTALLATION, MONITORING AND TESTING

Installation

The installation steps for construction of a soil nail wall are shown schematically on Figure 1.2.1 and discussed below.

Step 1 - Excavation - Soil Nail walls are built from the top down. Therefore, it is imperative to have a soil that will stand near vertical for the time it will take to anchor and shotcrete or stabilize the wall face. For permanent shotcrete-faced walls, excavation should be made as close to the plan grade as possible, as additional excavation will need to be replaced with additional shotcrete thickness. For temporary walls, excavation limits are not as critical. However, excavation control is needed during construction of a temporary wall to ensure

that the ultimate wall face does not go beyond or inside the area where the permanent wall is to be built. Excavation should proceed to a depth below the nail elevation that will facilitate installation and maintain a stable ground condition. This is typically 2 to 3 feet below the nail elevation, but no more than 5 feet to satisfy OSHA regulations.

Alternate for Unstable Ground - If soft or unstable ground is encountered during construction, there are several alternatives. If the ground is sloughing prior to nailing or shotcrete placement, a flash coat of shotcrete can be placed immediately after excavation to stabilize the face. Soil nails can then be drilled through the shotcrete and a final shotcrete coat applied after nail installation. If the ground will not stand vertically during excavation, then a berm and slotting technique can be used. The soil should be excavated to a stable angle of repose, such that ground at the top of the slope is outside the wall face. Then a vertical trench, wide enough to allow for soil nail installation, typically one or two backhoe widths, is excavated just below the elevation for the soil nail. After soil nail installation is complete for a specified length of wall, the berm is excavated vertically in short stable steps and flash coated. Once the entire step is excavated and flash coated, wire mesh and shotcrete are placed.

While these methods may help to overcome isolated poor ground conditions on a project, these methods can be expensive and time consuming. Therefore, if these conditions are anticipated for all or part of a project, alternative means of support (i.e., Soldier Beams with CHANCE® Tieback Anchors) should be considered. The driving force of the soil nail wall and the driving force is the horizontal component of the thrust on the vertical plane at the back of the nails (Figures 3.4.1, 3.4.2 and 3.4.3.).

Step 2 - Screw Anchor Installation - Once a stable excavation is constructed, the anchors can be installed. The anchors should be installed along the excavated face within 6 inches of their plan location. First, the lead section, either 5 or 7 feet long, is installed. The anchor should be aligned on the correct angle from the horizontal, as required on the plans. This can be monitored by placement of a level and protractor on the equipment being used to drill the anchors. Once aligned, the anchor should be pushed into the ground up to the first helix (approx. 6 inches), and then drilled or screwed into the soil to a depth that allows the next extension to be bolted onto the lead. The extension should be bolted on with the nut tightened to 40 ft-lbs., and then screwed into the ground. Anchor installation should proceed until the depth required on the plans is achieved.

Step 3 - Shotcrete Placement - Prior to placing shotcrete, drainage composites and welded wire mesh should be placed along the excavated wall face. Any loose soil in areas where sloughing has occurred should be removed. Drainage composite is placed in between the anchors, as shown on the plans, and in any additional areas where excess seepage is observed. The composite should be unrolled down the wall face, and the unrolled section at the bottom of the wall should be covered with plastic in a trench below the area to be shotcreted. The top of the drain should be secured against the soil face so that it will not move during shotcrete placement. In the same way, the welded wire mesh or rebar should be placed over the composite and tied off to the nail heads. The bearing plate should also be attached to the end of the nail and be placed at a proper distance into the wall face, as shown on the plans. This is often done between the application of an initial half-thickness layer of shotcrete and the final finish facing.

Before shotcrete is placed, a small berm or wooden form board (typically 6 inch to 8 inch tall) should be placed at the bottom of the excavation (Figure 4.4.1) to facilitate construction of subsequent lifts. This berm will allow for lapping of the wire mesh and provides a joint under which subsequent levels of shotcrete can be placed.

Quality shotcrete is best obtained by experienced nozzle men directing the shotcrete perpendicular to the wall face. This will minimize voids and sand pockets around the rebar or mesh, and maximizes bond of concrete to soil. It also minimizes the amount of excess concrete used by reducing rebound.

Step 4 - Subsequent Excavation and Screw Anchor Installation - Excavation for the next layer of anchors and shotcrete proceeds as in Step 1. Great care must be exercised to protect the work that is in place. In particular, the shotcrete, nail heads and the strip drains should be protected from damage by excavating equipment. Once the excavation is complete, construction proceeds as outlined in Step 2.

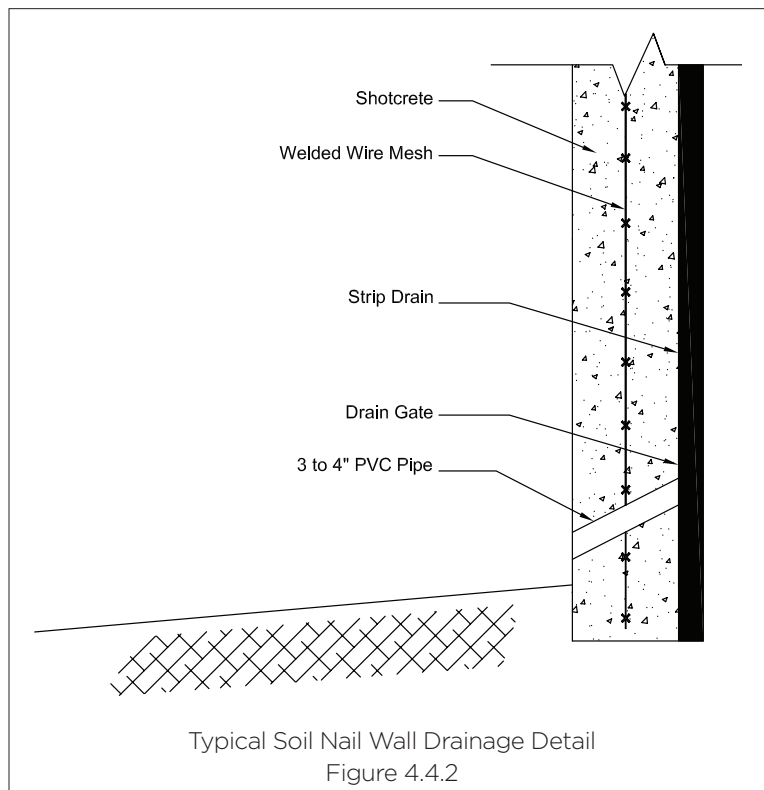
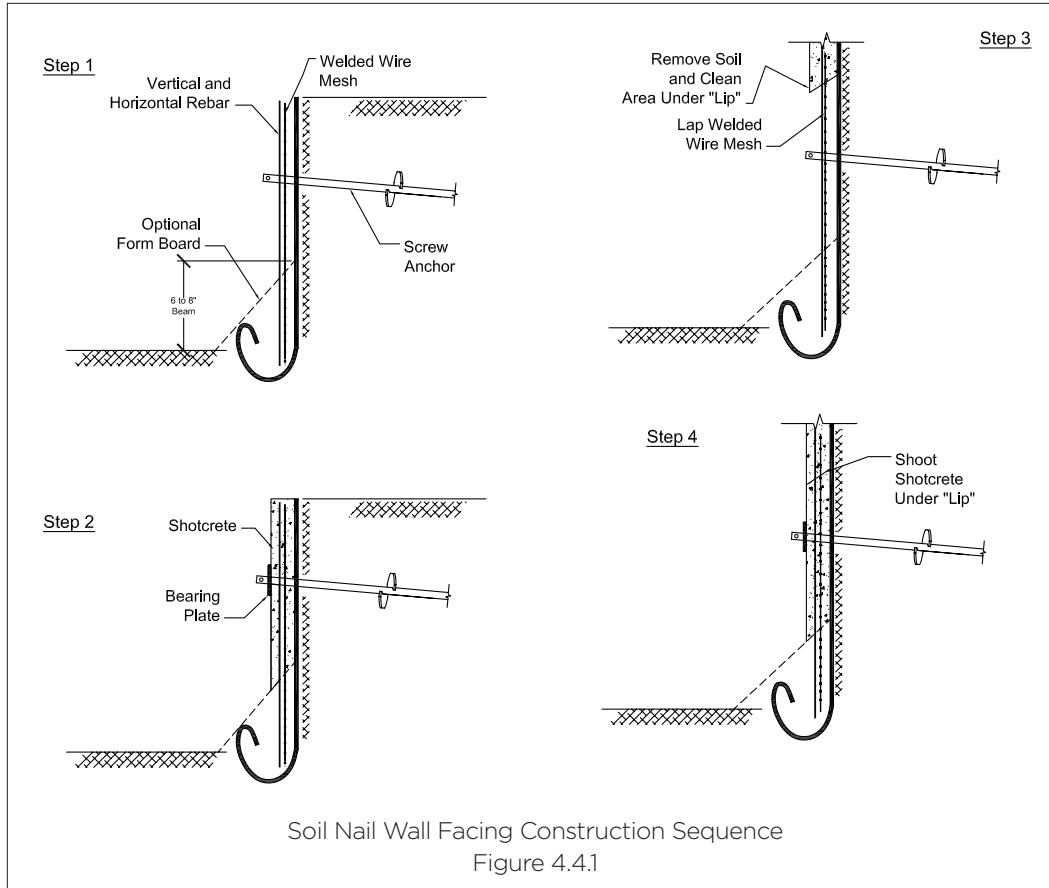

Step 4a - Subsequent Shotcrete Lift Installation - The area beneath the cold joint of the first shotcrete layer should be cleaned, and any loose particles removed by compressed air. The strip drain should then be rolled down, as in Step 3 (if damaged, a new section is placed with the damaged section removed per the manufacturer recommendations). Wire mesh or rebar is lapped under the shotcrete lip and #4 bar waler placed behind the plates for the nail head. The berm at the bottom of the excavation (see Fig. 4.4.1) is applied beneath the joint and progresses in the manner described in Step 3.

Step 4 is repeated until the required depth of excavation is obtained. If weep holes are designed into the wall face, these are installed, as shown on Figure 4.4.2, prior to shooting the shotcrete on the final lift. If a trench drain and footing is used, this can also be installed prior to placing the final shotcrete lift.

Step 5 - Install the Permanent Face - If a permanent facing is designed, then the rebar for this system is placed over the temporary shotcrete face, and the final shotcrete layer is placed. Alignment for the wall plumbness should be monitored during installation of the shotcrete layer. Oftentimes a thin series of wires is used to show the location of the wall face during shotcrete placement. Shotcrete is then placed and struck off to the level set by the wires.

Monitoring and Testing

All excavations, whether permanent or temporary, should be monitored regularly for movement during construction. Monitoring should include a daily walking inspection of the wall by the superintendent or foreman and the Engineer. Indications of movement or distress in the wall can include:

- Cracks developing behind the wall face
- Settlement or distress of adjacent structures or soil
- Cracks in the shotcrete facing.
- Heaving of the excavation in front of the wall
- Seepage through the wall face

If there are signs of movement or distress to the wall, steps must be taken immediately to investigate and correct any problem. This may include revising the construction techniques (smaller excavation lifts, using berms and slotting during excavation, etc.), providing additional drainage if required, monitoring the wall using survey monuments for a period of time, limiting surcharge, or possible redesign of the wall by including additional nails. In any case, the cause of distress must be uncovered, and actions taken quickly, to prevent further wall distress.

For walls that will be greater than 10 feet in height, or wall with structures located above the wall, surveying of the wall for monitoring wall movement should be performed in addition to the daily field inspections. Some wall movement is to be expected as the wall is built. Therefore, it is important to locate survey points on the wall as excavation proceeds and to establish benchmarks that will not be disturbed by construction or other work on site.

Regular surveying does not need to be performed on a daily basis unless there are indications of excessive movement of the wall, or there have been significant events, such as heavy rains or earthquakes. Monitoring should be logged over time to track any trends in the wall movement that may not be visible in daily inspections.

Anchors should be tested to confirm their capacity (bond stress) and long term serviceability (creep). Non-production anchors are used for testing. The testing loads should not exceed 80% of the ultimate strength of the screw anchor being tested, and therefore, this will limit the length of the screw anchor. The anchors used for testing should consist of a length compatible with the limits of 80% of the ultimate strength and include a length of plain extension bar. This will enable the anchors to be installed to the typical depths for the project behind a typical failure plane and have smooth extensions, which will not bond with soil in the active wedge. Test screws can then be tested for bond and for creep, as discussed in the specifications in Appendix B.

SPECIFICATIONS SECTION 5

CONTENTS

PRODUCT SPECIFICATIONS.....	5-2
PERFORMANCE SPECIFICATION.....	5-2

DISCLAIMER

The information in this manual is provided as a guide to assist you with your design and in writing your own specifications.

Installation conditions, including soil and structure conditions, vary widely from location to location and from point to point on a site.

Independent engineering analysis and consulting state and local building codes and authorities should be conducted prior to any installation to ascertain and verify compliance to relevant rules, regulations and requirements.

Hubbell Power Systems, Inc., shall not be responsible for, or liable to you and/or your customers for the adoption, revision, implementation, use or misuse of this information. Hubbell, Inc., takes great pride and has every confidence in its network of installing contractors and dealers.

Hubbell Power Systems, Inc., does NOT warrant the work of its dealers/installing contractors in the installation of CHANCE® Civil Construction foundation support products.

SPECIFICATIONS

PRODUCT SPECIFICATIONS (OWNER-DESIGNED WALLS WITH PRODUCT SPECIFICATIONS)

This type of specification assumes that the owner or owner’s engineer has designed the wall using the CHANCE® SOIL SCREW® Retention Wall System. The specification provides all the requirements for the contractor, materials, installation and testing, and refers to completed plans that show the design of the wall and location of all nails.

An example specification is provided in Appendix B. This specification is written for permanent walls and covers excavation and anchor installation. Specifications for a particular facing system should be added or included on the plans.

PERFORMANCE SPECIFICATION (DESIGN-BUILD SPECIFICATION WITH PERFORMANCE REQUIREMENTS)

This type of specification assumes a geotechnical investigation has been performed at the site. A review of that investigation shows that soil nailing is feasible and an economical option for the project. The specification is a request from the owner to a design build contractor to provide a bid to design and build the wall based upon design and performance standards and testing requirements set out in the specification.

An example specification is provided in Appendix B.

REFERENCES SECTION 6

REFERENCES

REFERENCES

DISCLAIMER

The information in this manual is provided as a guide to assist you with your design and in writing your own specifications.

Installation conditions, including soil and structure conditions, vary widely from location to location and from point to point on a site.

Independent engineering analysis and consulting state and local building codes and authorities should be conducted prior to any installation to ascertain and verify compliance to relevant rules, regulations and requirements.

Hubbell Power Systems, Inc., shall not be responsible for, or liable to you and/or your customers for the adoption, revision, implementation, use or misuse of this information. Hubbell, Inc., takes great pride and has every confidence in its network of installing contractors and dealers.

Hubbell Power Systems, Inc., does NOT warrant the work of its dealers/installing contractors in the installation of CHANCE® Civil Construction foundation support products.

REFERENCES

- AASHTO Highway Subcommittee on Bridges and Structures (1978), "Manual on Foundation Investigations," American Association of State Highway and Transportation Officials.
- Clemence, S.P., Crouch, L.K., and R.W. Stephenson (1994), "Prediction of Uplift Capacity for Helical Anchors in Sand", Proceedings, Second Geotechnical Engineering Conference, Cairo University.
- Das, B. M. (1985), "Resistance of Shallow Inclined Anchors in Clay," Proceedings, Uplift Behavior of Anchor Foundations in Soil, ASCE, pp. 86-101.
- Federal Highway Administration Publication No. FHWA-SA-93-026, "Recommendations Clouterre 1991 (English Translation)", August , 1993.
- Federal Highway Administration Publication No. FHWA-SA-96-069, "Manual for Design and Construction Monitoring of Soil Nail Walls, November 1996.
- Federal Highway Administration Publication No. FHWA-SA-96-071, "Mechanically Stabilized Earth Walls and Reinforced Soil Slopes Design and Construction Guidelines."
- Federal Highway Administration Publication No. FHWA-SA-96-072, "Corrosion/ Degradation of Soil Reinforcement for Mechanically Stabilized Earth Walls and Reinforced Soil Slopes."
- Hoshiya, M., and J. N. Mandal (1984), "Some Studies on Anchor Plates in Sand," Soils and Foundations, JSSMFE, Vol. 24, No. 1, pp. 9-16.
- Hoyt, R. M., and S. P. Clemence (1989), "Uplift Capacity of Helical Anchors in Soil," 12th ICSMFE, Vol. 2, pp. 1019-1022.
- Meyerhof, G. G. (1973), "Uplift Resistance of Inclined Anchors and Piles," Proceedings, 8th ICSMFE, Vol. 2, pp. 167-172.
- Mitsch, M. P., and S. P. Clemence (1985), "The Uplift Capacity of Helix Anchors in Sand," Proceedings, Uplift Behavior of Anchor Foundations in Soil, ASCE, pp. 26-47.
- Mooney, J. S., Adamczak, S. Jr. and S.P. Clemence. (1985), "Uplift Capacity of Helical Anchors in Clay and Silt," Proceedings, Uplift Behavior of Anchor Foundations in Soil, ASCE, pp. 48-72.
- Rapaport, V., and A. G. Young (1985), "Uplift Capacity of Shallow Offshore Foundations, " Proceedings, Uplift Behavior of Anchor Foundations in Soil, ASCE, pp. 73-85.
- Stewart, W. (1985), "Uplift Capacity of Circular Plate Anchors in Layered Soil," Canadian Geotechnical Journal, Vol. 22, pp. 589-592.
- Yilmaz, M., and T. H. Hanna (1971), "The Interaction of Groups of Anchors in Sand," Symposium on the Interaction of Structure and Foundation, Birmingham, England, pp. 196-205.

REFERENCES

DESIGN CHARTS AND DESIGN EXAMPLES APPENDIX A

CONTENTS

APPENDIX A1 - DESIGN CHARTS	A-3
FIGURE A-1 SOIL SCREW® RETENTION WALL SYSTEM PRELIMINARY DESIGN CHART.....	A-3
FIGURE A-2 SOIL SCREW® RETENTION WALL SYSTEM PRELIMINARY DESIGN CHART.....	A-3
FIGURE A-3 SOIL SCREW® RETENTION WALL SYSTEM PRELIMINARY DESIGN CHART.....	A-4
APPENDIX A2 - DESIGN EXAMPLES.....	A-5
ATTACHMENT EX1 - INTERNAL STABILITY USING GOLDNAIL.....	A-13
ATTACHMENT EX2 - GLOBAL STABILITY ANALYSIS USING STABL.....	A-21

CHARTS & EXAMPLES

DISCLAIMER

The information in this manual is provided as a guide to assist you with your design and in writing your own specifications.

Installation conditions, including soil and structure conditions, vary widely from location to location and from point to point on a site.

Independent engineering analysis and consulting state and local building codes and authorities should be conducted prior to any installation to ascertain and verify compliance to relevant rules, regulations and requirements.

Hubbell Power Systems, Inc., shall not be responsible for, or liable to you and/or your customers for the adoption, revision, implementation, use or misuse of this information. Hubbell, Inc., takes great pride and has every confidence in its network of installing contractors and dealers.

Hubbell Power Systems, Inc., does NOT warrant the work of its dealers/installing contractors in the installation of CHANCE® Civil Construction foundation support products.

APPENDIX A1 - DESIGN CHARTS

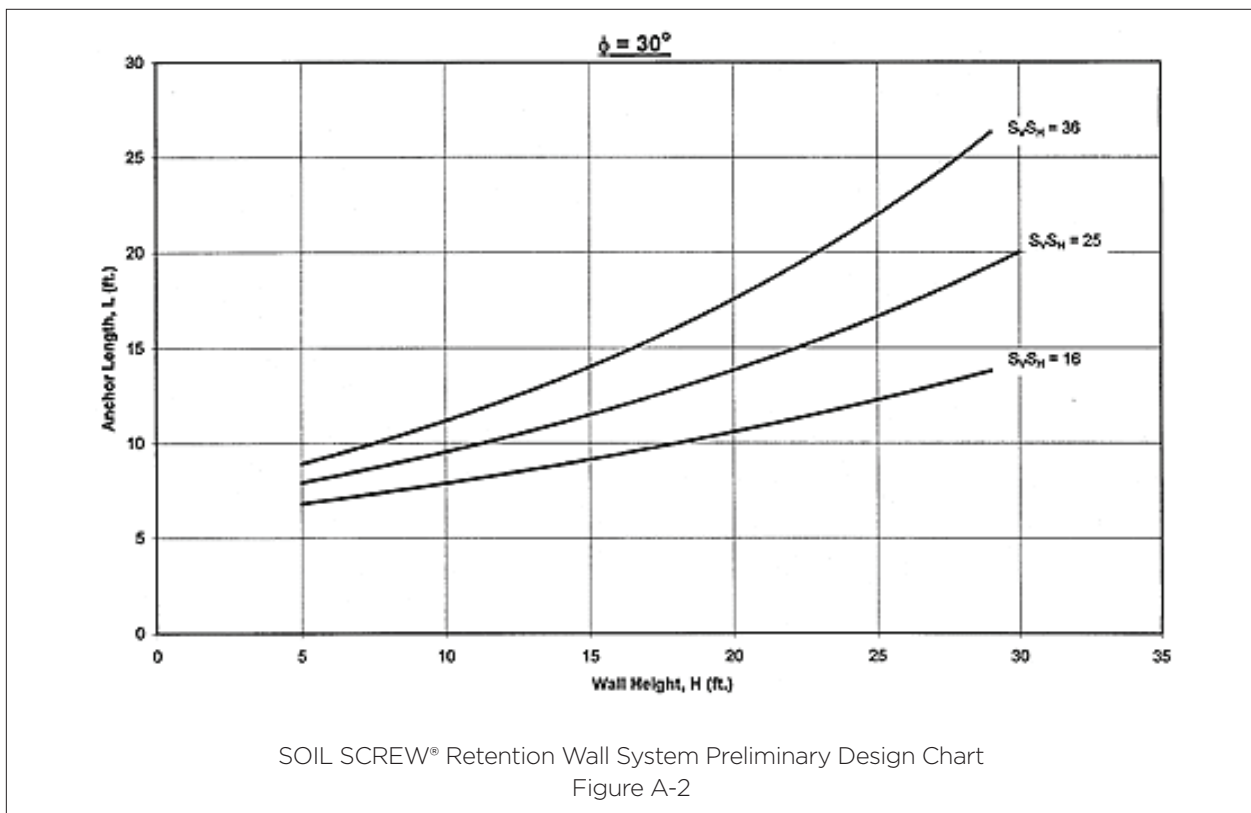
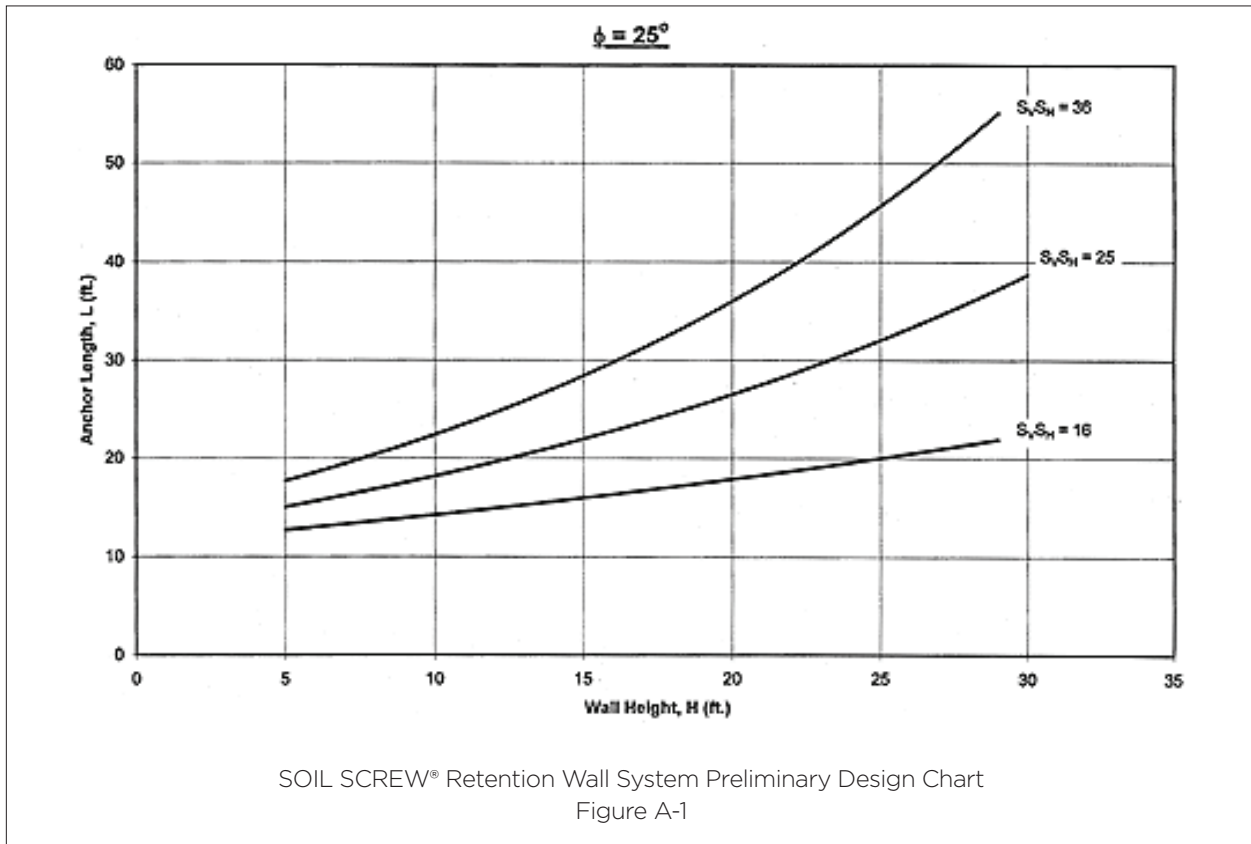

CHARTS & EXAMPLES

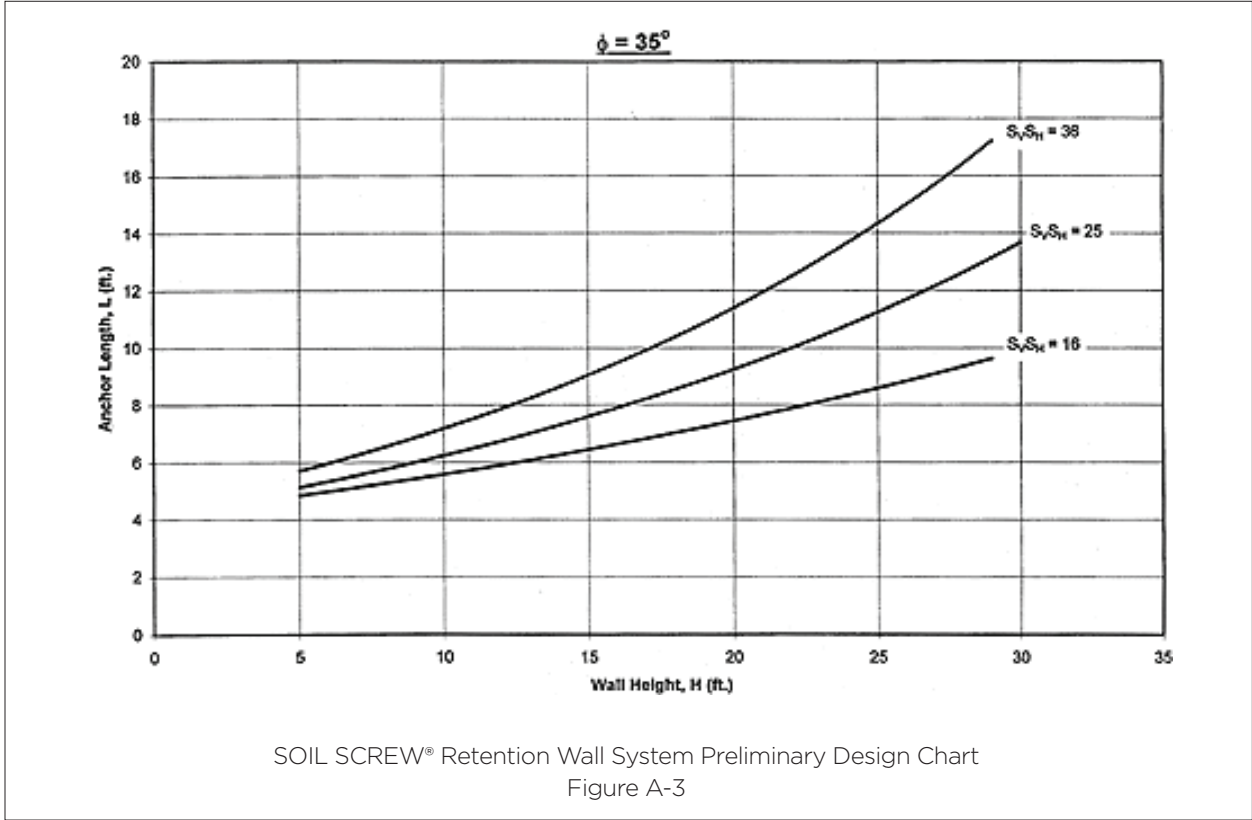

APPENDIX A2 – DESIGN EXAMPLE

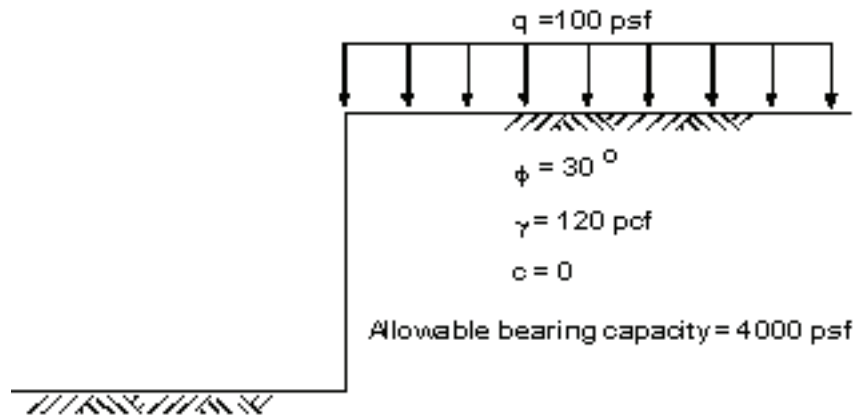

Determine the screw anchor spacing (SV, SH), screw anchor length and facing requirements for an excavation support system for a 23-foot deep excavation in a silty sand.

The required design factor of safety for internal stability is 1.5, and for global stability is 1.3.

Step 1 - Define Design Parameters

Given: The unit weight and friction angle of the silty sand is 120 pcf and 30° respectively. The allowable bearing capacity of the silty sand at the bottom of the excavation is 4000 psf.

The electrochemical properties of the silty sand are listed below:

Resistivity	4000 ohm-cm
pH	7
Chlorides	50 ppm
Sulfates	100 ppm

A design live surcharge load of 100 psf is considered to be applied uniformly across the ground surface at the top of the wall. The wall face is vertical. Groundwater is located 60 feet below the ground surface.

CHANCE® Type SS5 Screw Anchors, for which lead sections and extensions are available in 5' and 7' lengths, are to be used for the screw anchors. The design life of the structure is one year. Design screw anchor lengths will be governed by the lead and extension pieces and thus will be 10', 12', 14', 15', 17', 19', etc.

Step 2 - Check the Preliminary Feasibility of the SOIL SCREW® Retention Wall System

The medium dense, silty sands at this site are well suited for the SOIL SCREW® Retention Wall System (i.e., good stand up time). The water table is well below the bottom of the excavation. The conditions at the site are therefore favorable for the SOIL SCREW® Retention Wall System.

Design charts are used to determine preliminary screw anchor spacing and lengths for the given wall geometry, loading and soil conditions. For the soil conditions, $\phi = 30^\circ$, enter the design chart (Figure A-2) along the x-axis at a wall height, $H = 23 \text{ ft}$. A typical screw anchor spacing for soils with “good” stand up time is 5 ft. x 5 ft. Therefore, use the $S_V S_H = 25$ curve to determine the preliminary screw anchor length, $L = 16 \text{ ft}$. (see Figure EX-1).

Step 3 - Determine External Earth Pressures

Use equation 3.1 to determine the earth pressure at the back of the reinforced soil mass.

$$K_a = \tan^2 (45-\phi/2)$$

$$K_a = \tan^2 (45-30/2) = 0.33$$

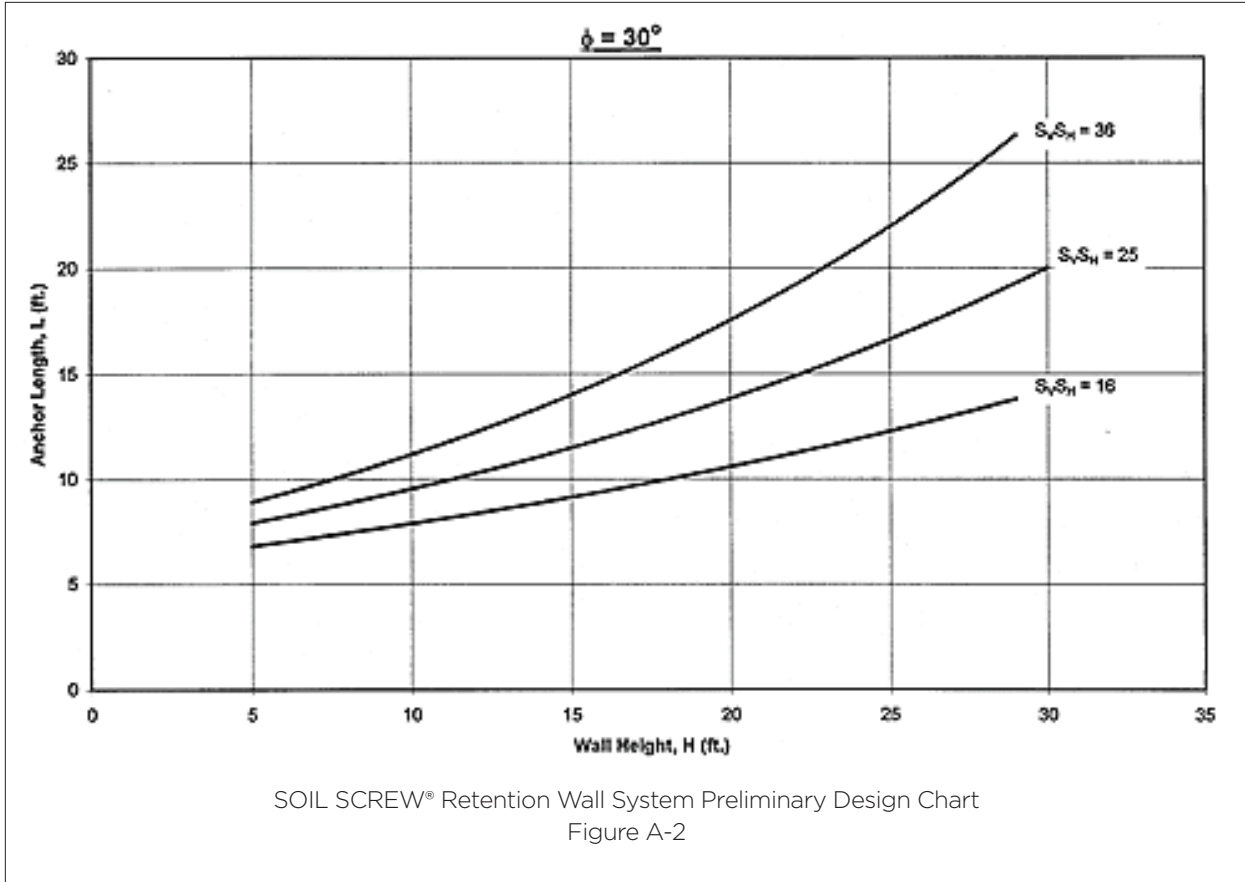

Step 4 - Check Preliminary Screw Anchor Length with Respect to Sliding

Available screw anchor lengths for CHANCE® SS5 Anchors are 10', 12', 14', 15', 17', 19', etc. The 16 ft. preliminary length determined in Step 2 does not account for surcharge loading, which tends to increase screw anchor lengths. Try 19' screw anchors (length to height ratio of 0.83). For preliminary designs, for walls with the given soil and loading conditions, a length to height ratio of 0.8 to 1.0 is a starting point for the analysis and appears to be conservative.

The horizontal force from the retained soil is determined using equation 3.5.

$$F_1 = 1/2 K_a \gamma H^2$$

$$F_1 = 1/2 0.33(120)23^2 = 10474 \text{ lb/lf of wall}$$

The horizontal force from the surcharge load is determined using equation 3.6.

$$F_2 = K_a q H = 0.33(100)23 = 759 \text{ lb/lf of wall}$$

Using 19' screw anchors installed at a 15° angle, the horizontal length, L_x , of the screw anchor is determined:

$$L_x = L \cos 15^\circ$$

$$L_x = 19 \cos 15^\circ = 18.4 \text{ ft}$$

The factor of safety against sliding is determined as follows:

$$F.S. = \frac{\gamma HL_x \tan \phi}{F_1 + F_2} = \frac{120(23)18.4 \tan 30}{10474 + 759}$$

$$F.S. = 2.61$$

Step 5 - Check Required Bearing Capacity at the Base of the Wall

Determine the eccentricity (e) of the resultant vertical force (equation 3.9):

$$e = \frac{F_1 \left(\frac{H}{3}\right) + F_2 \left(\frac{H}{2}\right)}{\gamma HL_x} = \frac{10474 \left(\frac{23}{3}\right) + 759 \left(\frac{23}{2}\right)}{120 (23)18.4}$$

$$1.75 < \frac{L_x}{6} = \frac{18.4}{6} = 3.06$$

The vertical stress of the bottom of the wall is determined as follows (equation 3.10):

$$\sigma_v = \frac{\gamma HL_x + qL_x}{L_x - 2e} = \frac{120(23)18.4 + 100(18.4)}{18.4 - 2(1.75)} = 3532 \text{psf}$$

Given the allowable bearing capacity is 4000 psf.

$$q_{\text{allow}} = 4000 \text{ psf} > \sigma_v = 3532 \text{ psf}$$

Step 6 - Determine the Allowable Screw Anchor Strength

The screw anchor wall is a temporary structure with a design life of one year. Using Table 3.5.2, the allowable design strength of the CHANCE® SS5 Anchor is 45 kips.

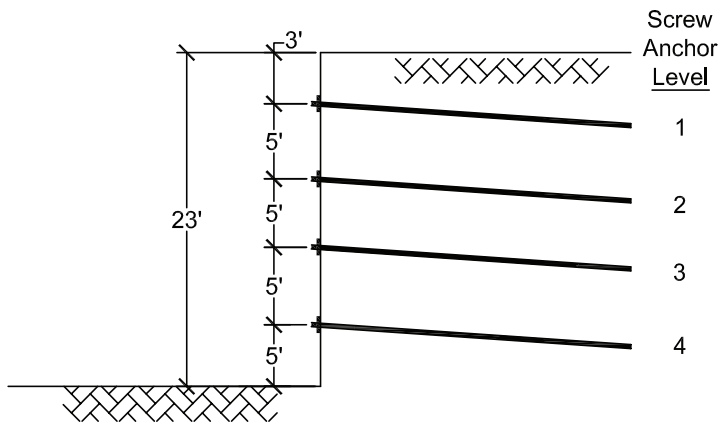

Step 7 - Estimate the Pullout Capacity of the Screw Anchors

Determine the bearing capacity factor for helical anchors for a sand with an effective friction angle, $\phi = 30^\circ$. From Figure 3.5.3, $N_q = 14$:

Using equation 3.14, determine the pullout capacity of the screw anchors.

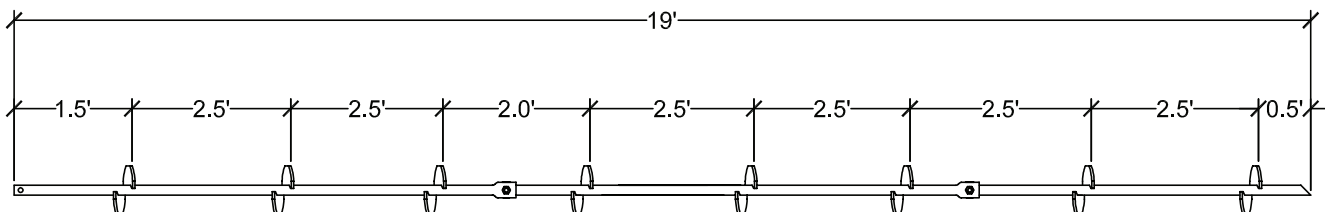

Assumed vertical spacing is 5 feet (Step 2). Nail pattern is as shown.

There are eight helices per anchor, as shown below.

The pullout capacity of the anchor at level 1 is determined as follows using equation 3.14:

$$P = \sum_{i=1}^{8_i} A_i q_i N_{qi}$$

Screw anchors have 8-inch diameter helices.

$$A = \pi (0.33)^2 = 0.34 \text{ ft}^2$$

The pullout capacities for the anchors at the various levels are determined as follows:

$$y = 19 \sin 15^\circ = 4.9 \text{ ft.}$$

Average overburden depth =

$$3 + \frac{y}{2} = 5.5 @ \text{level 1}$$

$$P_{\text{level 1}} = 8(0.34)5.5(120)14 = 25 \text{ kips}$$

$$P_{\text{level 2}} = 8(0.34)10.5(120)14 = 48 \text{ kips}$$

$$P_{\text{level 3}} = 8(0.34)15.5(120)14 = 71 \text{ kips}$$

$$P_{\text{level 4}} = 8(0.34)20.5(120)14 = 94 \text{ kips}$$

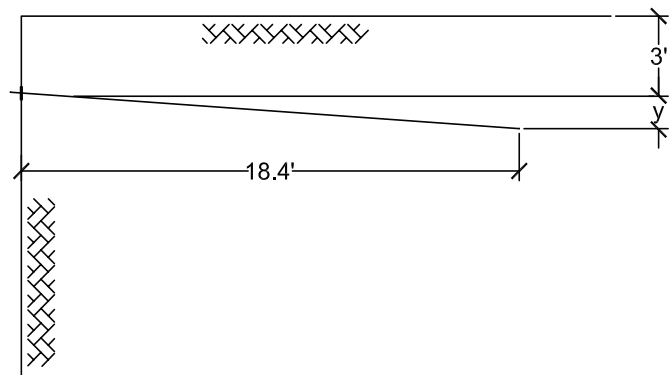

Step 8 - Define a Trial Facing System

Try a 4 inch thick, 4000 psi shotcrete face with 6 x 6, W2.9 x W2.9 welded wire mesh reinforcing and 2- #4 vertical rebars at screw anchor locations. Try a screw anchor spacing of 5 feet vertically and horizontally and an 8" square by 3/4" thick bearing plate with a steel yield stress of 36 ksi.

Step 9 - Determine the Allowable Flexural Strength of the Facing

For typical soil nail wall construction practice, the facing is analyzed using vertical strips of width equal to the horizontal anchor spacing. For facing systems involving horizontal nail spacings that are larger than the vertical spacing or unit horizontal moment capacities that are less than the vertical unit moment capacities, horizontal strips of width equal to the vertical anchor spacing should be used.

The area of steel for a vertical beam of width 5 feet ($S_H = 5$ feet) with the anchor on the beam's centerline is determined as follows:

Diameter (d) of the W2.9 x W2.9 welded fabric wire is 0.192 inches

Diameter (D) of the #4 rebar is 0.500 inches

$$A_{s, \text{neg}} = \left(\frac{pd^2}{4} \right) \left(\frac{\text{in.}^2}{\text{wire}} \right) \times \left(\frac{2 \text{ wires}}{\text{ft.}} \right) \times 5 \text{ ft} + \left(\frac{pD^2}{4} \right) \left(\frac{\text{in.}^2}{\text{rebar}} \right) \times \left(\frac{2 \text{ rebars}}{5 \text{ ft.}} \right) \times 5 \text{ ft}$$

$$= \frac{p(0.192)^2}{4} \times 2 \times 5 + \left(\frac{p(0.500)^2}{4} \right) \times 2 = 0.682 \text{ in.}^2$$

For a 5 ft. wide vertical beam centered between the anchors, the #4 rebars are located at the beam edges and should be ignored. The area of steel is calculated as:

$$A_{s, \text{pos}} = \left(\frac{\pi d^2}{4} \right) \left(\frac{\text{in.}^2}{\text{wire}} \right) \times \left(\frac{2 \text{wires}}{\text{ft.}} \right) \times 5 \text{ft} = \frac{\pi(0.192)^2}{4} \times 2 \times 5 = 0.289 \text{in.}^2$$

The corresponding average nominal unit moment resistances are determined using equation 3.15 as shown below:

$$m_v = \frac{A_s F_y \left(d - \frac{A_s F_y}{1.7 f'_c b} \right)}{b}$$

$$m_{v, \text{neg}} = \frac{0.682(60) \left(2 - \frac{0.682(60)}{1.7(4)(5 \times 12)} \right)}{5 \times 12}$$

$$= 1.30 \text{k} - \text{in/in}$$

$$= 1.30 \text{k} - \text{ft/ft}$$

$$m_{v, \text{pos}} = \frac{0.289(60) \left(2 - \frac{0.289(60)}{1.7(4)(5 \times 12)} \right)}{5 \times 12}$$

$$= 0.556 \text{k} - \text{ft/ft}$$

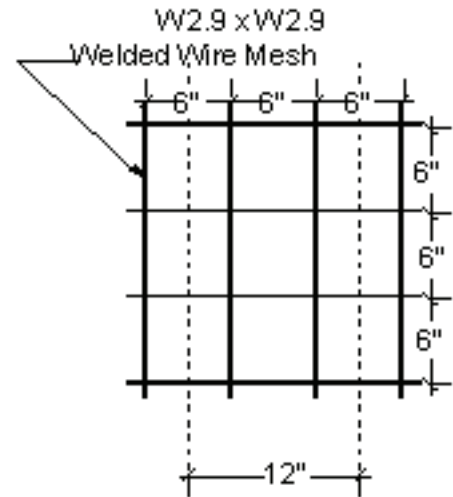

Step 10 - Determine the Maximum Screw Anchor Head Load that will Produce the Allowable Moments Determined in Step 9, using Equation 3.16:

$$T_{FN, \text{flexure}} = C_F (m_{v, \text{neg}} + m_{v, \text{pos}}) 8 \left(\frac{SH}{SV} \right)$$

Using Table 3.5.4, determine C_F for temporary shotcrete facing 4 inches thick $C_F = 2.0$

$$T_{FN, \text{flexure}} = 2(1.30 + 0.57) 8 \left(\frac{5 \text{ft}}{5 \text{ft}} \right) = 29.8 \text{ kips}$$

Step 11 - Determine the Allowable Punching Shear Strength of the Facing

The punching shear strength is determined using equation 3.17:

$$V_N = 0.125 \sqrt{f'_c} \pi D'_c h_c$$

$$V_N = 0.125 \sqrt{4} \pi (12)(4) = 38 \text{ kips}$$

where:

$$f'_c = 4,000 \text{ psi} = 4 \text{ ksi}$$

$$h_c = 4 \text{ in.}$$

$$D'_c = 8 + 4 = 12 \text{ in.}$$

Step 12 - Determine Critical Screw Anchor Head Load for Punching

$$T_{FN,punching} = V_N = 38 \text{ kips}$$

Step 13 - Construct Screw Anchor Strength Envelope

Construct the strength envelope at each anchor level as shown below. At the wall face, the nail head flexural strength is less than the nail head punching strength and therefore controls. There are eight helices per anchor. Each step in strength equals the single-helix bearing capacity for the nail layer (Step 7). From the last helix (working from right to left) increase the pullout capacity in a stepwise fashion. If the pullout envelope working from the back of the nail does not intersect the flexural limit line, the strength envelope will look like that shown for Anchor 1. If the pullout envelope working from the back of the nail exceeds the flexural limit, then construct a pullout envelope working from the flexural limit at the head of the nail.

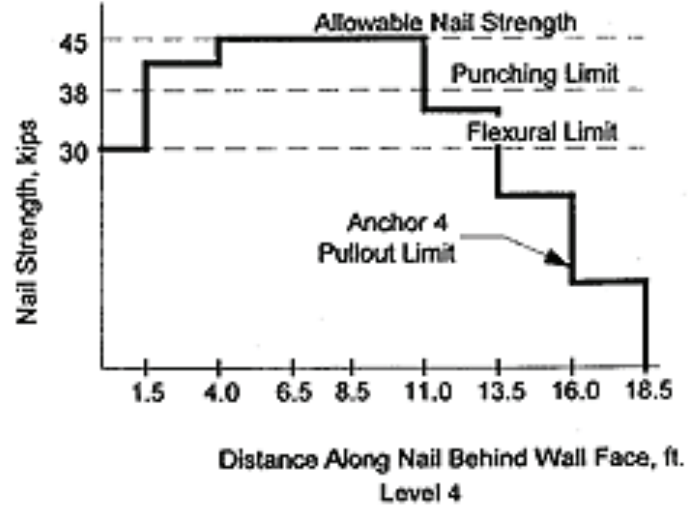
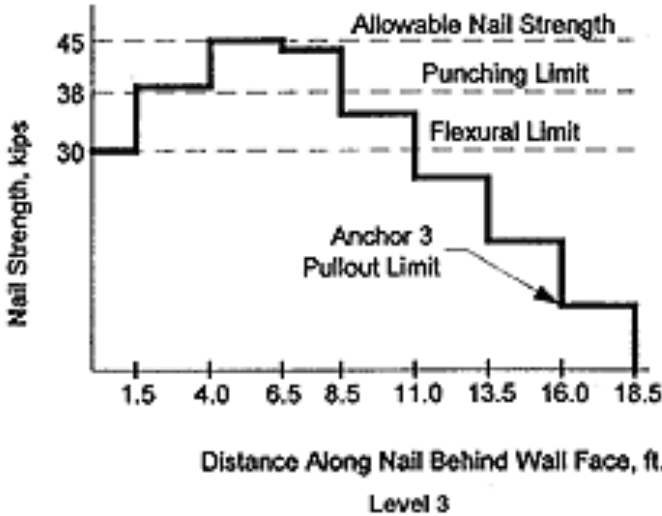
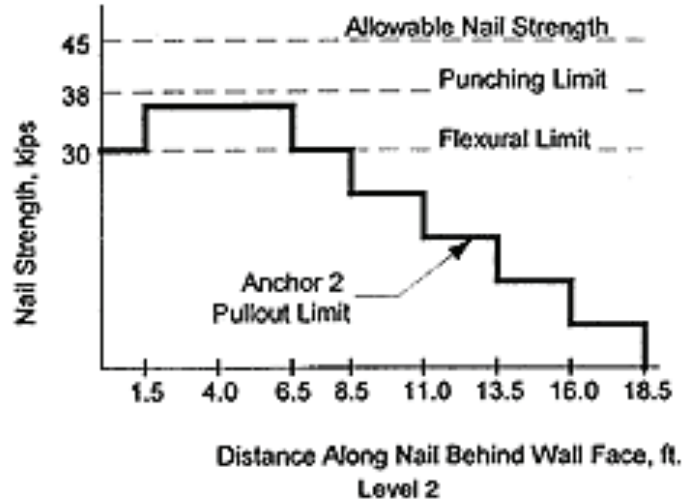
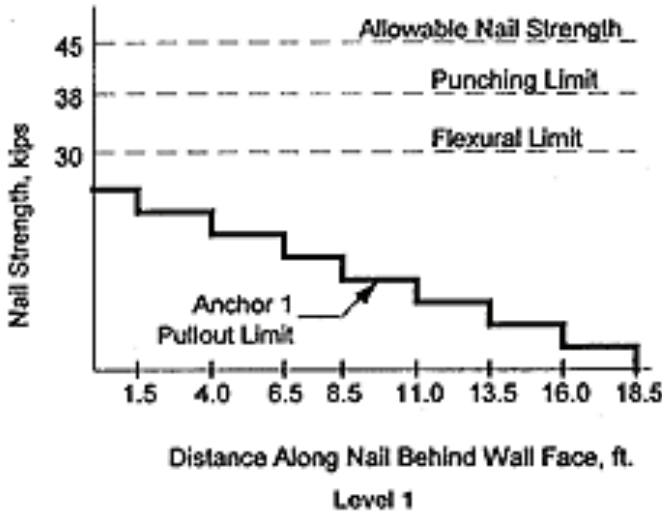

CHARTS & EXAMPLES

Step 14 - Evaluate Internal and Compound Stability.

GoldNail 3.11, A Stability Analysis Computer Program for Soil Nail Wall Design, developed by Golder & Associates, was used to perform the internal and compound stability analysis.

The nail strength envelope developed in Step 13 needs to be modified for GoldNail. The increase in pullout capacity along the length of the nail is estimated for GoldNail as straight lines not step functions. An example of this modification for anchor level 2 is shown below:

Within GoldNail there are several analysis options. The option used for this example is Factor of Safety. Using this option, the internal Factor of Safety, $FS_{\text{internal}} = 2.11$ for the nail pattern defined in Step 7. See attached computer printout (Attachment EX1). The GoldNail output printout lists Global Stability not Internal Stability. However, the location of the critical failure surface (circle no. 13) indicates an internal mode of failure, as shown on the GoldNail geometry printout.

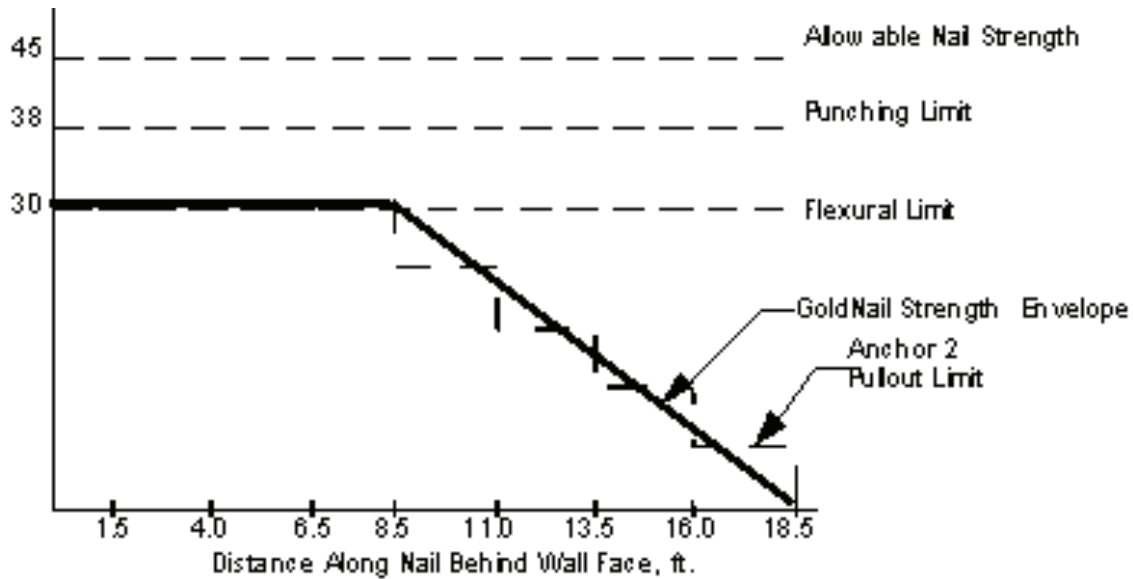

Step 15 - Check Global Stability

Analysis performed for the given slope geometry by the computer program PCSTABL6H, developed by Purdue University and modified by Harald Van Aller, and the pre-processor STED, developed by Harald Van Aller. The resulting global Factor of Safety, $FS_{\text{global}} = 1.93$. See attached computer printout (Attachment EX2).

Step 16 - Check Cantilever at Top of Wall

In Step 7 layout of anchor was assumed. The cantilever at the top of the wall from Step 7 is 3 feet. Using equation 3.20 check cantilever moment:

$$M_c = K_a \gamma \left[\left(\frac{H_1^2}{2} \right) \left(\frac{H_1^2}{3} \right) + q \left(\frac{H_1^2}{2} \right) \right]$$

$$= 0.33 \left[0.33 \left(\frac{3^2}{2} \right) \left(\frac{3}{3} \right) + 100 \left(\frac{3^2}{2} \right) \right]$$

$$= 326.7 \text{ lb} - \text{ft/ft}$$

$$FS_{MC} = \frac{566}{327} = 1.73 \quad \text{O.K.}$$

Maximum allowable moment at midspan (Step 9) is 566 lb-ft/ft.

Check shear force at cantilever using equation 3.2.0:

$$\begin{aligned} S_c &= K_a \left[\gamma \left(\frac{H_1^2}{2} \right) + qH_1 \right] \\ &= 0.33 \left[120 \left(\frac{3^2}{2} \right) + 100(3) \right] \\ &= 277 \text{ lb/ft} \end{aligned}$$

Determine maximum allowable shear using equation 3.2.1:

$$\begin{aligned} V_N &= 0.125 \sqrt{f'_c} h_c \\ &= 0.125 \sqrt{4(4)} = 1000 \text{ lb/lf} \end{aligned}$$

$$FS_{\text{shear}} = \frac{1000}{277} = 3.6 \quad \text{O.K.}$$

ATTACHMENT EXAMPLE 1: Internal Stability Analysis Using GoldNail

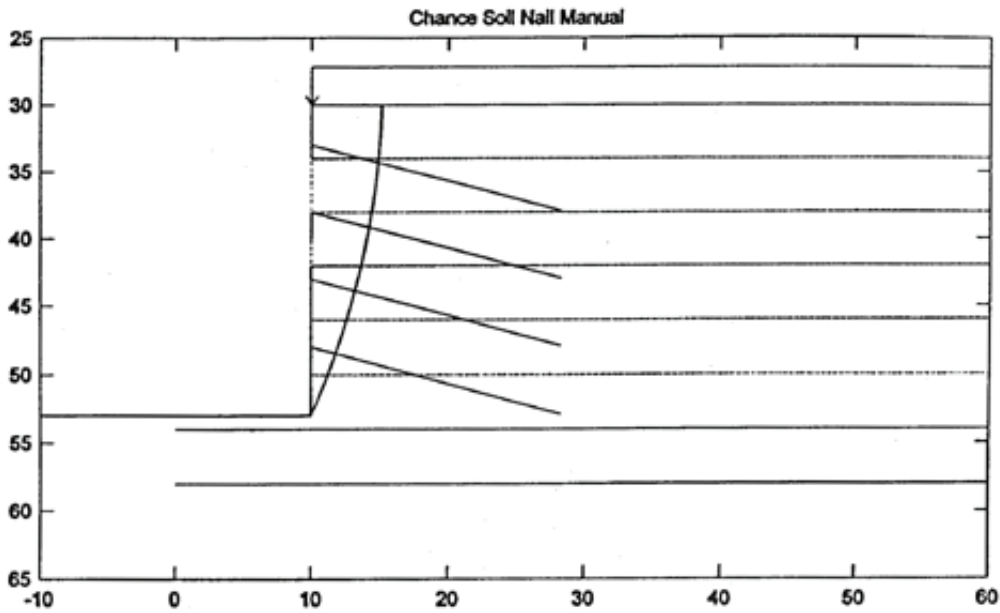

ATTACHMENT EXAMPLE 1: Internal Stability Analysis Using GoldNail Page 1

Chance Soil Nail Manual

General Data	
File Identifier	SCREW-EX.GNI
Unit weight of water	0.062
Base depth for analysis	23.0
Seismic Coefficient	0.0
Minimum Base Exit Angle	-10.0
X Search limit (left)	10.023
X Search limit (right)	70.0
Number of slip circles	150
No. of slip circle exits	20

LRFD and Safety Factor Data	
Analysis Mode: (L)RFD or (S)LD (specify L or S)	S
- SLD Safety and Strength Factors (mode S only)	
FS for Soil Cohesion	1
FS for Soil Friction	1
Strength Factor for Head Strength	1
Strength Factor for Nail Tendon Strength	1
Strength Factor for Nail Pullout Resistance	0.5
- LRFD Load Factors (mode L only)	
LF for Unit Weight of Water	1
LF for Unit Weight of Soil	1.35
LF for Surcharge Loads	1.75
LF for Seismic Loads	1
- LRFD Resistance Factors (mode L only)	
RF for Soil Cohesion	1
RF for Soil Friction Angle	0.75
RF for Head Strength	0.9
RF for Nail Pullout Resistance	0.7
RF for Nail Tendon Strength	0.9

PIEZOMETRIC DATA	X-Value	Piez. Level
Point 1		
Point 2		
Point 3		
Point 4		
Point 5		
Point 6		
Point 7		
Point 8		
Point 9		
Point 10		

CHARTS & EXAMPLES

ATTACHMENT EXAMPLE 1: Internal Stability Analysis Using GoldNail Page 2

Nodal Data								
Node No	X-Value	Y-Value	Node No	X-Value	Y-Value	Node No	X-Value	Y-Value
1	0	58	16	70	38	31		
2	0	54	17	70	34	32		
3	10	53	18	70	30	33		
4	10.003	50	19			34		
5	10.007	46	20			35		
6	10.011	42	21			36		
7	10.015	38	22			37		
8	10.019	34	23			38		
9	10.023	30	24			39		
10	70	58	25			40		
11	70	54	26			41		
12	70	53	27			42		
13	70	50	28			43		
14	70	46	29			44		
15	70	42	30			45		

Wall Segment Data									
Seg. No.	Node 1	Node 2	Soil ID	Pullout Res. ID	Seg. No.	Node 1	Node 2	Soil ID	Pullout Res. ID
1	3	4	1	6	11				
2	4	5	1	5	12				
3	5	6	1	4	13				
4	6	7	1	3	14				
5	7	8	1	2	15				
6	8	9	1	1	16				
7					17				
8					18				
9					19				
10					20				

Surface Segment Data							
Seg. No.	Node 1	Node 2	Soil ID	Seg. No.	Node 1	Node 2	Soil ID
1	9	18	1	11			
2				12			
3				13			
4				14			
5				15			
6				16			
7				17			
8				18			
9				19			
10				20			

ATTACHMENT EXAMPLE 1: Internal Stability Analysis Using GoldNail Page 3

Internal Segment Data									
Seg. No.	Node 1	Node 2	Soil ID	Pullout Res. ID	Seg. No.	Node 1	Node 2	Soil ID	Pullout Res. ID
1	1	10	1	8	11				
2	2	11	1	7	12				
3	4	13	1	6	13				
4	5	14	1	5	14				
5	6	15	1	4	15				
6	7	16	1	3	16				
7	8	17	1	2	17				
8					18				
9					19				
10					20				

Soil Strength & Pullout Resist. Data				
Material ID No.	c	s	Unit Weight	Pullout Res.
1	0	35	0.12	0.82
2	0	0	0	2.47
3	0	0	0	4.12
4	0	0	0	5.77
5	0	0	0	7.41
6	0	0	0	9.06
7	0	0	0	10.71
8	0	0	0	12.36
9	0	0	0	14
10				
11				
12				
13				
14				

Surcharge Pressure Data			
Load No	X-value	Vert.	Horiz.
1	70	0.1	0
2			
3			
4			
5			
6			
7			
8			
9			
10			

CHARTS & EXAMPLES

ATTACHMENT EXAMPLE 1: Internal Stability Analysis Using GoldNail Page 4

Nail Data	Nail Depth	Nail Length	Tendon Strength	Head Strength	Fixed Nail?
Nail Row 1	3	19	45	30	
Nail Row 2	8	19	45	30	
Nail Row 3	13	19	45	30	
Nail Row 4	18	19	45	30	
Nail Row 5					
Nail Row 6					
Nail Row 7					
Nail Row 8					
Nail Row 9					
Nail Row 10					
Nail Row 11					
Nail Row 12					
Nail Row 13					
Nail Row 14					
Nail Row 15					
Horiz. Spacing	5				
Nail Declination	15				



ATTACHMENT EXAMPLE 1: Internal Stability Analysis Using GoldNail Page 5

Global Stability

Minimum global safety factor = 2.027 for circle no. 13

Output Data

Wall Height = 23.00
Wall Slope = 89.94

Circle Number	Circle X-Intercept	Circle Base Angle	Circle X-Center	Circle Y-Center	Moment Ratio	Factor of Safety
1	10.05	89.83	-11489.97	18.50	1.000	2.61
2	10.93	87.63	-11489.53	-423.54	1.000	2.45
3	11.89	85.26	-11489.05	-901.35	1.000	2.34
4	11.89	81.56	-164.20	27.14	1.000	2.19
5	12.90	82.77	-11488.55	-1406.58	1.000	2.26
6	12.90	79.07	-163.69	19.45	1.000	2.15
7	13.97	80.15	-11488.01	-1943.09	1.000	2.22
8	13.97	76.45	-163.16	11.28	1.000	2.14
9	13.97	72.75	-75.89	26.34	0.999	2.07
10	15.11	77.41	-11487.44	-2515.65	1.000	2.19
11	15.11	73.71	-162.58	2.56	1.000	2.11
12	15.11	70.01	-75.31	21.96	1.000	2.06
13	15.11	66.31	-45.76	28.53	0.999	2.03
14	16.34	74.52	-11486.82	-3130.17	1.000	2.15
15	16.34	70.82	-161.97	-6.80	1.000	2.09
16	16.34	67.13	-74.70	17.27	1.000	2.06
17	16.34	63.43	-45.14	25.42	0.999	2.05
18	16.34	59.73	-30.19	29.54	0.998	2.05
19	17.67	71.50	-11486.16	-3794.12	1.000	2.13
20	17.67	67.80	-161.30	-16.91	1.000	2.09
21	17.67	64.10	-74.03	12.19	1.000	2.07
22	17.67	60.40	-44.48	22.05	0.999	2.08
23	17.67	56.70	-29.52	27.04	0.998	2.10
24	19.12	68.32	-11485.44	-4517.01	1.000	2.12
25	19.12	64.62	-160.58	-27.92	1.000	2.10
26	19.12	60.92	-73.31	6.67	0.999	2.10
27	19.12	57.22	-43.76	18.38	0.999	2.12
28	19.12	53.52	-28.80	24.31	0.998	2.16
29	19.12	49.82	-19.70	27.92	0.998	2.19
30	20.71	64.98	-11484.64	-5311.18	1.000	2.13
31	20.71	61.28	-159.79	-40.02	1.000	2.13
32	20.71	57.58	-72.52	0.60	0.999	2.15
33	20.71	53.88	-42.96	14.36	0.999	2.17
34	20.71	50.19	-28.00	21.32	0.998	2.19
35	20.71	46.49	-18.91	25.55	0.997	2.21
36	20.71	42.79	-12.75	28.42	0.996	2.25
37	22.47	61.48	-11483.76	-6192.92	1.000	2.15
38	22.47	57.78	-158.91	-53.45	1.000	2.17
39	22.47	54.08	-71.64	-6.14	0.999	2.17
40	22.47	50.38	-42.08	9.89	0.999	2.18
41	22.47	46.68	-27.12	18.00	0.998	2.20
42	22.47	42.98	-18.03	22.93	0.996	2.24
43	22.47	39.28	-11.87	26.26	0.995	2.27
44	22.47	35.58	-7.39	28.69	0.994	2.32
45	24.45	57.80	-11482.77	-7184.15	1.000	2.18
46	24.45	54.10	-157.91	-68.54	1.000	2.16
47	24.45	50.40	-70.64	-13.71	0.999	2.16
48	24.45	46.70	-41.09	4.86	0.998	2.18
49	24.45	43.00	-26.13	14.26	0.997	2.22
50	24.45	39.30	-17.04	19.97	0.996	2.26
51	24.45	35.60	-10.88	23.84	0.994	2.31
52	24.45	31.90	-6.40	26.65	0.992	2.37
53	24.45	28.21	-2.97	28.81	1.003	2.40

CHARTS & EXAMPLES



ATTACHMENT EXAMPLE 1: Internal Stability Analysis Using GoldNail Page 6

Output Data						
Wall Height = 23.00						
Wall Slope = 89.94						
Circle Number	Circle X-Intercept	Circle Base Angle	Circle X-Center	Circle Y-Center	Moment Ratio	Factor of Safety
54	26.71	53.94	-11481.64	-8315.12	1.000	2.15
55	26.71	50.24	-156.78	-85.77	1.000	2.15
56	26.71	46.54	-69.51	-22.35	0.999	2.16
57	26.71	42.84	-39.96	-0.88	0.998	2.20
58	26.71	39.14	-25.00	9.99	0.996	2.23
59	26.71	35.44	-15.90	16.60	0.994	2.27
60	26.71	31.74	-9.75	21.08	0.992	2.32
61	26.71	28.04	-5.27	24.33	0.990	2.38
62	26.71	24.34	-1.84	26.82	1.001	2.40
63	26.71	20.64	0.88	28.80	1.000	2.49
64	29.34	49.88	-11480.33	-9628.77	1.000	2.13
65	29.34	46.18	-155.47	-105.77	1.000	2.14
66	29.34	42.48	-68.20	-32.39	0.999	2.15
67	29.34	38.78	-38.65	-7.54	0.998	2.16
68	29.34	35.08	-23.69	5.04	0.996	2.19
69	29.34	31.39	-14.59	12.69	0.994	2.23
70	29.34	27.69	-8.43	17.87	0.991	2.28
71	29.34	23.99	-3.96	21.63	0.999	2.30
72	29.34	20.29	-0.53	24.51	0.998	2.38
73	29.34	16.59	2.20	26.81	0.995	2.47
74	29.34	12.89	4.44	28.69	0.993	2.56
75	32.46	45.62	-11478.77	-11188.24	1.000	2.12
76	32.46	41.92	-153.91	-129.52	1.000	2.12
77	32.46	38.22	-66.64	-44.31	0.999	2.11
78	32.46	34.53	-37.09	-15.45	0.998	2.13
79	32.46	30.83	-22.13	-0.84	0.996	2.16
80	32.46	27.13	-13.03	8.04	0.993	2.20
81	32.46	23.43	-6.87	14.06	1.000	2.22
82	32.46	19.73	-2.40	18.43	0.998	2.28
83	32.46	16.03	1.03	21.77	0.995	2.35
84	32.46	12.33	3.76	24.44	0.992	2.45
85	32.46	8.63	6.00	26.63	1.005	2.47
86	32.46	4.93	7.88	28.47	1.002	2.54
87	36.26	41.15	-11476.86	-13090.34	1.000	2.10
88	36.26	37.45	-152.01	-158.49	1.000	2.09
89	36.26	33.75	-64.74	-58.84	0.999	2.10
90	36.26	30.05	-35.18	-25.09	0.997	2.13
91	36.26	26.35	-20.22	-8.01	0.995	2.17
92	36.26	22.66	-11.13	2.38	0.992	2.20
93	36.26	18.96	-4.97	9.41	1.000	2.20
94	36.26	15.26	-0.50	14.52	0.997	2.26
95	36.26	11.56	2.93	18.43	0.994	2.33
96	36.26	7.86	5.66	21.55	1.007	2.37
97	36.26	4.16	7.90	24.11	1.005	2.42
98	36.26	0.46	9.79	26.26	1.004	2.45
99	36.26	-3.24	11.41	28.11	1.001	2.50
100	36.26	-6.94	12.83	29.74	0.999	2.57
101	41.07	36.46	-11474.46	-15491.53	1.000	2.14
102	41.07	32.76	-149.61	-195.06	1.000	2.13
103	41.07	29.06	-62.34	-77.19	0.999	2.14
104	41.07	25.36	-32.78	-37.27	0.998	2.14
105	41.07	21.66	-17.82	-17.06	0.996	2.16
106	41.07	17.96	-8.73	-4.78	0.993	2.21
107	41.07	14.26	-2.57	3.54	1.002	2.26
108	41.07	10.56	1.91	9.59	0.998	2.35
109	41.07	6.86	5.33	14.22	0.996	2.37
110	41.07	3.16	8.06	17.90	0.992	2.39
111	41.07	-0.54	10.30	20.93	1.001	2.38

CHARTS & EXAMPLES



ATTACHMENT EXAMPLE 1: Internal Stability Analysis Using GoldNail Page 7

Output Data						
Wall Height = 23.00						
Wall Slope = 89.94						
Circle Number	Circle X-Intercept	Circle Base Angle	Circle X-Center	Circle Y-Center	Moment Ratio	Factor of Safety
112	41.07	-4.24	12.19	23.47	1.001	2.43
113	41.07	-7.94	13.81	25.67	1.008	2.52
114	47.41	31.53	-11471.29	-18662.53	1.000	2.20
115	47.41	27.83	-146.44	-243.35	1.000	2.18
116	47.41	24.13	-59.17	-101.42	0.999	2.20
117	47.41	20.43	-29.61	-53.35	0.998	2.26
118	47.41	16.73	-14.65	-29.02	0.997	2.32
119	47.41	13.03	-5.56	-14.22	0.994	2.40
120	47.41	9.33	0.60	-4.21	0.990	2.40
121	47.41	5.63	5.08	3.07	1.005	2.34
122	47.41	1.93	8.50	8.65	1.003	2.38
123	47.41	-1.77	11.23	13.08	0.998	2.47
124	47.41	-5.47	13.47	16.73	0.992	2.57
125	47.41	-9.17	15.36	19.79	1.001	2.64
126	56.32	26.35	-11466.84	-23116.37	1.000	2.37
127	56.32	22.65	-141.98	-311.18	1.000	2.42
128	56.32	18.95	-54.71	-135.45	0.999	2.47
129	56.32	15.25	-25.16	-75.93	0.998	2.53
130	56.32	11.55	-10.20	-45.81	0.996	2.51
131	56.32	7.85	-1.10	-27.49	0.993	2.52
132	56.32	4.15	5.05	-15.09	1.001	2.56
133	56.32	0.46	9.53	-6.08	1.001	2.62
134	56.32	-3.24	12.96	0.82	1.001	2.68
135	56.32	-6.94	15.69	6.32	1.001	2.74
136	70.00	20.92	-11460.00	-29958.49	1.000	2.77
137	70.00	17.22	-135.14	-415.39	1.000	2.83
138	70.00	13.52	-47.87	-187.73	1.000	2.81
139	70.00	9.82	-18.32	-110.63	0.999	2.87
140	70.00	6.12	-3.36	-71.60	0.998	2.95
141	70.00	2.42	5.74	-47.88	0.995	3.01
142	70.00	-1.28	11.90	-31.81	0.991	3.06
143	70.00	-4.98	16.37	-20.14	1.001	3.06
144	70.00	-8.68	19.80	-11.20	1.001	3.16

CHARTS & EXAMPLES

ATTACHMENT EXAMPLE 2: Global Stability Analysis Using STABL GoldNail

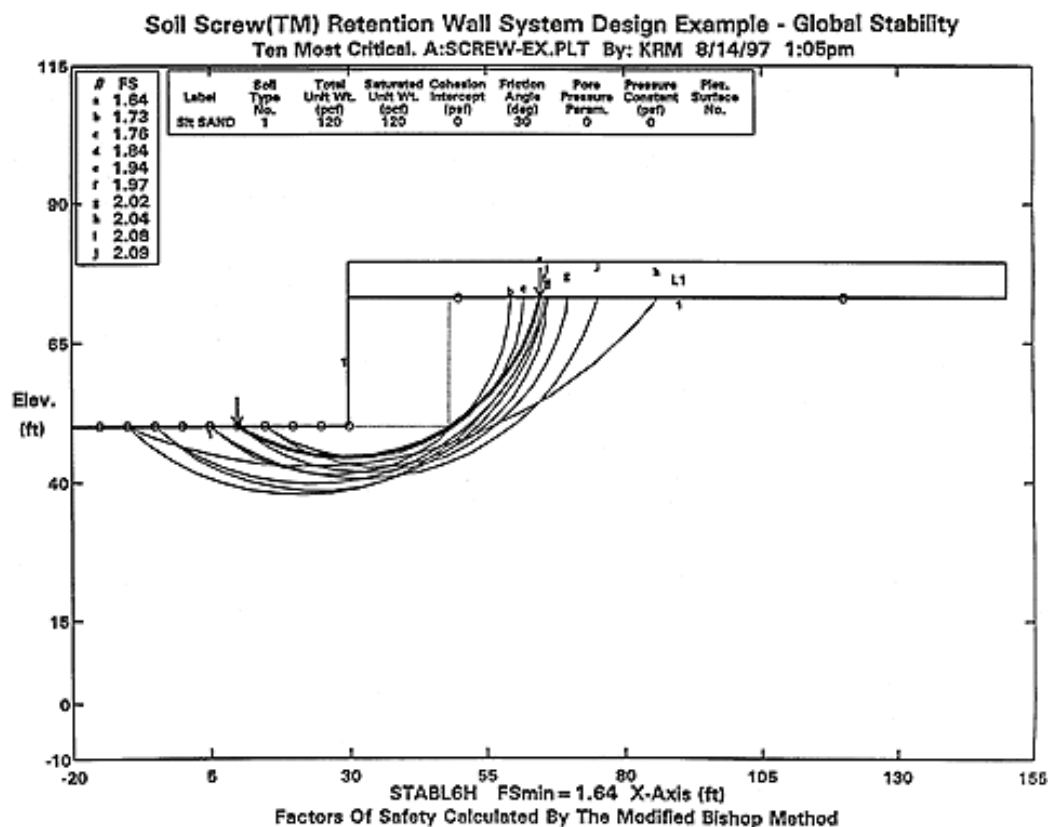

** STABL6H **
 by
 Purdue University

--Slop Stability Analysis--
 Simplified Jandu, Simplified Bishop
 or Spencer's Method of Slices

Run Date: 8/14/97
 Time of Run: 1:05pm
 Run By: KRM
 Input Data Filename: A:SCREW-EX.DAT
 Output Data Filename: A:SCREW-EX.OUT
 Plotted Output Filename: A:SCREW-EX.PLT

PROBLEM DESCRIPTION

SOIL SCREW® Retention Wall System Design Example - Global Stability

BOUNDARY COORDINATES

3 Top Boundaries
3 Total Boundaries

Boundary No.	X-Left (ft)	Y-Left (ft)	X-Right (ft)	Y-Right (ft)	Soil T Below
1	.00	60.00	50.00	60.00	1
2	50.00	60.00	50.01	83.00	1
3	50.01	83.00	170.00	83.00	1

ISOTROPIC SOIL PARAMETERS

1 Type(s) of Soil

Soil Type No.	Total Unit Wt. (pcf)	Saturated Unit Wt. (pcf)	Cohesion Intercept (psf)	Friction Angle (deg)	Pore Pressure Param.	Pressure Pi Constant Su (psf)
1	120.0	120.0	.0	30.0	.00	.0

BOUNDARY LOAD(S)

1 Load(s) Specified

Load No.	X-Left (ft)	X-Right (ft)	Intensity (lb/sqft)	Deflection (deg)
1	50.01	170.00	100.0	.0

NOTE - Intensity is specified as a uniformly distributed force acting on a horizontally projected surface.

Searching routine will be limited to an area defined by 2 bound of which the first 0 boundaries will deflect surfaces upward.

Boundary No	S-Left (ft)	Y-Left (ft)	X-Right (ft)	Y-Right (ft)
1	50.00	60.00	68.30	60.00
2	68.30	60.00	68.40	83.00

A critical failure surface searching method, using a random technique for generating circular surfaces, has be specified.

100 Trial surfaces have been generated.

10 surfaces initiate from eac of 10 points equall space along the ground surface between x = 5.00 ft. and x = 50.00 ft.

Each surface terminates between x = 70.00 ft. and x = 140.00 ft.

Unless further limitations were imposed, the minimum elevation at which a surface extends is Y = .00 ft.

5.00 ft line segments define each trial failure surface.

The factor of safety for the trial failure surface defined by the coordinates listed below is misleading.

Failure surface defined by 24 coordinate points

Point No.	X-Surf (ft)	Y-Surf (ft)
1	50.00	61.15
2	53.54	57.61
3	58.41	66.56
4	62.61	69.28
5	66.80	72.00
6	70.99	74.74
7	70.41	82.59
8	76.49	45.89
9	81.47	45.48
10	86.47	45.49
11	91.45	45.92
12	96.38	46.77
13	101.21	48.04
14	105.93	49.71
15	110.48	51.77
16	114.85	54.21
17	118.99	57.01
18	122.88	60.15
19	126.49	63.61
20	129.80	67.36
21	132.77	71.38
22	135.40	75.63
23	137.66	80.09
24	138.84	83.00

Factor of Safety for the preceding specified surface = 1.669

Following are displayed the ten most critical of the trail failure surfaces examined. They are ordered - most critical first.

** Safety factors are calculated by the Modified Bishop Method

Failure Surface specified by 15 coordinate points

Point No.	X-Surf (ft)	Y-Surf (ft)
1	30.00	60.00
2	34.40	57.62
3	39.08	55.86
4	43.96	54.77
5	48.94	54.36
6	53.93	54.64
7	58.84	55.61
8	63.56	57.24
9	68.02	59.52
10	72.11	62.39
11	75.78	65.78
12	78.94	69.66
13	81.53	73.93
14	83.51	78.53
15	84.74	83.00

Circle center at X = 49.4 ; Y = 90.5 and radius, 36.2

*** 1.639 ***

Failure surface specified by 16 coordinate points

Point No.	X-Surf (ft)	Y-Surf (ft)
1	25.00	60.00
2	28.91	56.88
3	33.24	54.39
4	37.91	52.60
5	42.80	51.56
6	47.79	51.27
7	52.77	51.76
8	57.61	53.00
9	62.21	54.98
10	66.44	57.63
11	70.22	60.91
12	73.44	64.73
13	76.05	69.00
14	77.96	73.62
15	79.14	78.48
16	79.52	83.00

Circle center at X= 47.1 ; Y = 83.7 and radius, 32.4

*** 1.727 ***

CHARTS & EXAMPLES

Failure surface specified by 14 coordinate points

Point No.	X-Surf (ft)	Y-Surf (ft)
1	35.00	60.00
2	39.29	57.43
3	43.95	55.62
4	48.58	54.62
5	53.85	54.46
6	58.80	55.14
7	63.57	56.65
8	68.01	58.94
9	72.01	61.94
10	75.44	65.57
11	78.22	69.73
12	80.25	74.30
13	81.49	79.15
14	81.80	83.00

Circle center at X= 52.3 ; Y = 84.0 and radius, 29.6

*** 1.762 ***

Failure surface specified by 19 coordinate points

Point No.	X-Surf (ft)	Y-Surf (ft)
1	15.00	60.00
2	19.01	57.01
3	23.32	54.49
4	27.90	52.47
5	32.67	50.98
6	37.58	50.05
7	42.57	49.67
8	48.58	49.86
9	52.51	50.62
10	57.33	51.93
11	61.98	53.77
12	66.39	56.13
13	70.50	58.98
14	74.27	62.27
15	77.64	65.96
16	80.56	70.01
17	83.02	74.37
18	84.96	78.98
19	86.14	83.00

Circle center at X= 43.4 ; Y = 93.8 and radius, 44.1

*** 1.839 ***

Failure surface specified by 20 coordinate points

Point No.	X-Surf (ft)	Y-Surf (ft)
1	15.00	60.00
2	18.84	56.80
3	23.03	54.07
4	27.51	51.85
5	32.22	50.16
6	37.09	49.04
7	42.06	48.49
8	47.06	48.52
9	52.02	49.14
10	56.22	50.34
11	61.56	52.09
12	66.00	54.38
13	70.15	57.17
14	73.95	60.42
15	77.34	64.10
16	80.28	68.14
17	82.72	72.50
18	84.64	77.12
19	86.01	81.93
20	86.18	83.00

Circle center at X= 44.3 ; Y = 91.2 and radius, 42.8

*** 1.940 ***

Failure surface specified by 21 coordinate points

Point No.	X-Surf (ft)	Y-Surf (ft)
1	10.00	60.00
2	13.84	56.79
3	18.00	54.03
4	22.44	51.73
5	27.11	49.93
6	31.94	48.66
7	36.89	47.92
8	41.89	47.73
9	46.87	48.08
10	51.79	48.98
11	56.58	50.41
12	61.19	52.35
13	65.56	54.79
14	69.63	57.69
15	73.36	61.01
16	76.71	64.73
17	79.69	68.79
18	82.08	73.34
19	84.05	77.74
20	85.50	82.52
21	85.59	83.00

Circle center at X= 41.2 ; Y = 93.4 and radius, 45.7

*** 1.968 ***

Failure surface specified by 17 coordinate points

Point No.	X-Surf (ft)	Y-Surf (ft)
1	30.00	60.00
2	34.09	57.12
3	38.53	54.82
4	43.24	53.14
5	48.12	52.11
6	53.12	51.75
7	58.11	52.07
8	63.01	53.05
9	67.73	54.69
10	72.19	56.95
11	76.31	59.79
12	80.00	63.16
13	83.21	66.99
14	85.87	71.23
15	87.93	75.78
16	89.36	80.57
17	89.74	83.00

Circle center at X= 53.3 ; Y = 88.7 and radius, 37.0

*** 2.019 ***

Failure surface specified by 23 coordinate points

Point No.	X-Surf (ft)	Y-Surf (ft)
1	10.00	60.00
2	14.62	58.09
3	19.35	56.48
4	24.18	55.15
5	29.07	54.13
6	34.02	53.41
7	39.00	53.00
8	44.00	52.90
9	49.00	53.10
10	53.97	53.62
11	58.90	54.44
12	63.77	55.56
13	62.57	56.98
14	73.26	58.70
15	77.85	60.70
16	82.29	62.98
17	68.59	65.53
18	90.73	71.41
19	97.68	71.41
20	98.44	74.71
21	101.89	78.23
22	105.30	81.97
23	106.11	83.00

Circle center at X= 43.2 ; Y = 133.8 and radius, 80.9

*** 2.035 ***

Failure surface specified by 15 coordinate points

Point No.	X-Surf (ft)	Y-Surf (ft)
1	35.00	60.00
2	39.08	57.11
3	43.57	54.92
4	48.36	53.47
5	53.31	52.80
6	58.31	52.93
7	63.23	53.86
8	67.93	55.57
9	72.29	58.00
10	76.22	61.11
11	79.58	64.79
12	82.33	68.97
13	64.37	73.54
14	85.65	78.37
15	86.11	83.00

Circle center at X= 55.0 ; Y = 83.9 and radius, 31.2

*** 2.078 ***

Failure surface specified by 19 coordinate points

Point No.	X-Surf (ft)	Y-Surf (ft)
1	25.00	60.00
2	29.11	57.15
3	33.51	54.78
4	38.15	52.92
5	42.97	51.59
6	47.91	50.81
7	52.91	50.59
8	57.89	50.93
9	62.81	51.82
10	67.60	53.27
11	72.19	55.24
12	76.54	57.71
13	80.58	60.66
14	84.26	64.04
15	87.54	67.81
16	90.38	71.93
17	92.74	76.34
18	94.58	80.99
19	94.13	83.00

Circle center at X= 52.4 ; Y = 95.1 and radius, 44.5

*** 2.086 ***

EXAMPLE SPECIFICATIONS (PERMANENT AND TEMPORARY) APPENDIX B

CONTENTS

APPENDIX B1 (OWNER-DESIGN) GUIDE SPECIFICATION
FOR SOIL SCREW® RETENTION WALL SYSTEM B-3

APPENDIX B2 (DESIGN-BUILD SOLICITATION) GUIDE
SPECIFICATION FOR SOIL SCREW® RETENTION
WALL SYSTEM..... B-13

SPECIFICATIONS

DISCLAIMER

The information in this manual is provided as a guide to assist you with your design and in writing your own specifications.

Installation conditions, including soil and structure conditions, vary widely from location to location and from point to point on a site.

Independent engineering analysis and consulting state and local building codes and authorities should be conducted prior to any installation to ascertain and verify compliance to relevant rules, regulations and requirements.

Hubbell Power Systems, Inc., shall not be responsible for, or liable to you and/or your customers for the adoption, revision, implementation, use or misuse of this information. Hubbell, Inc., takes great pride and has every confidence in its network of installing contractors and dealers.

Hubbell Power Systems, Inc., does NOT warrant the work of its dealers/installing contractors in the installation of CHANCE® Civil Construction foundation support products.

APPENDIX B1: GUIDE SPECIFICATION FOR SOIL SCREW® RETENTION WALL SYSTEMS (OWNER-DESIGN)

DESCRIPTION

The Work shall consist of constructing permanent SOIL SCREW® Retention Wall System as specified herein and shown on the Plans. The Contractor shall furnish all labor, materials and equipment required for completing the Work. The Contractor shall select the method of excavation, drilling method and equipment, to meet the performance requirements specified herein.

Soil nail walls are built from the top down in existing ground. The work shall include excavating in accordance with the staged lifts shown in the Plans; installing screw anchors to the specified minimum length and orientation indicated on the Plans; providing and placing drainage elements; placing shotcrete reinforcement; applying shotcrete facing over the reinforcement; attaching bearing plates and nuts; performing nail testing; and installing instrumentation (if required). Shotcrete facing and wall drainage construction is covered by the Shotcrete Facing and Wall Drainage Specification. CIP concrete facing construction (if required) is covered by the Standard Specifications and/or CIP Facing Special Provisions. Wall instrumentation (if required) is covered by the SOIL SCREW® Retention Wall System Instrumentation Specification.

The term “soil nail” as used in these specifications, refers to a screw anchor.

Soil properties, strength parameters, safety factors, design requirements and other criteria are shown on the Plans. In addition to the subsurface information presented in the Plans, Geotechnical Report(s) titled _____ are also available to bidders and can be obtained from _____.

Soil Nail Contractor’s Experience Requirements and Submittal - The soil nailing Contractor shall submit a project reference list verifying the successful construction completion of at least 3 permanent soil nail retaining wall projects during the past 3 years, totaling at least 10,000 square feet of wall face area and at least 500 permanent soil nails. Alternatively, experience of 2 projects using screw anchor tiebacks totaling 750 square meters over the past 3 years is acceptable. A brief description of each project with the Owner’s name and current phone number shall be included.

A Registered Professional Engineer employed by the soil nailing Contractor and having experience in the construction of permanent soil nail retaining walls on at least 3 completed projects over the past 3 years shall supervise the Work. The on-site supervisor and drill rig operators shall have experience installing permanent soil nails on at least 3 projects over the past 3 years.

At least 30 calendar days before starting the wall, the soil nail Contractor shall submit 5 copies of the completed project reference list and a list identifying the supervising Engineer, drill rig operators, and on-site supervisors assigned to the project. The personnel list shall contain a summary of each individual’s experience and be complete enough for the Engineer to determine whether each individual satisfies the required qualifications. The Engineer will approve or reject the Contractor’s qualifications within 1 calendar day after receipt of a complete submission. Work shall not be started nor materials ordered until the Engineer’s written approval of the Contractor’s qualifications is given.

The Engineer may suspend the Work if the Contractor uses non-approved personnel. If work is suspended, the Contractor shall be fully liable for all resulting costs, and no adjustment in contract time will result from the suspension.

Construction Site Survey - Before bidding the Work, the Contractor shall review the available subsurface information and visit the site to assess the site geometry, equipment access conditions, and location of existing structures and above-ground facilities.

The Contractor is responsible for field locating and verifying the location of all utilities shown on the Plans prior to starting the Work. Maintain uninterrupted service for those utilities designated to remain in service throughout the Work. Notify the Engineer of any utility locations different from those shown on the Plans that may require nail relocations or wall design modification. Subject to the Engineer’s approval, additional cost to the Contractor due to nail relocations and/or wall design modification resulting from utility locations different from shown on the Plans will be paid as Extra Work.

Prior to start of any wall construction activity, the Contractor and Engineer shall jointly inspect the site to observe and document the pre-construction condition of the site, existing structures and facilities. During construction, the Contractor shall observe the conditions above the soil nail wall on a daily basis for signs of ground movement in the vicinity of the wall. Immediately notify the Engineer if signs of movements such as new cracks in structures, increased size of old cracks

or separation of joints in structures, foundations, streets or paved and unpaved surfaces are observed. If the Engineer determines that the movements exceed those anticipated for typical soil nail wall construction and require corrective action, the Contractor shall take corrective actions necessary to stop the movement or perform repairs. When due to the Contractor's methods or operations or failure to follow the specified/approved construction sequence, as determined by the Engineer, the costs of providing corrective actions will be borne by the Contractor. When due to differing site conditions, as determined by the Engineer, the costs of providing corrective actions will be paid as Extra Work.

Construction Submittals - Upon approval of the soil nailing Contractor's qualifications submittal set forth in Section 1.1, submit 5 copies of the following information, in writing, to the Engineer for review and approval.

Provide submittal item numbers 1 through 1D at least 15 calendar days prior to initiating the soil nail wall construction and submittal items 2 through 4 at least 15 calendar days prior to start of nail installation or incorporation of the respective materials into the Work:

1. The proposed start date and proposed detailed wall construction sequence including:
 - 1A. Plan describing how surface water will be diverted, controlled and disposed of.
 - 1B. Proposed methods and equipment for excavating the soil and/or rock (if applicable) to the staged excavation lifts indicated in the Plans, including the proposed grade elevations for each excavation lift shown on a wall elevation view.
 - 1C. Measures to ensure wall and slope stability during various stages of wall construction and excavation where discontinuous rows of nails will be installed (if applicable); information on space requirements for installation equipment; temporary shoring plans (if applicable); information on provisions for working in the proximity of underground facilities or utilities (if applicable).
 - 1D. Proposed nail drilling methods and equipment including screw anchor type proposed to achieve the specified pullout resistance values and any variation of these along the wall alignment.
2. Proposed nail testing methods and equipment setup including:

Details of the jacking frame and appurtenant bracing.

Details showing methods of isolating test nails during shotcrete application (i.e., methods to prevent bonding of the screw anchor and the shotcrete facing during testing, if tested after shotcreting).

Equipment list.
3. Identification number and certified calibration records for each test jack and pressure gauge and load cell to be used. Jack and pressure gauge shall be calibrated as a unit. Calibration record shall include the date tested, device identification number, and the calibration test results and shall be certified for an accuracy of at least 2 percent of the applied certification loads by a qualified independent testing laboratory within 90 days prior to submittal.
4. Manufacturer Certificates of Compliance for the Screw Anchors

The Engineer will approve or reject the Contractor's submittals within 15 calendar days after receipt of a complete submission. The Contractor will not be allowed to begin wall construction or incorporate materials into the work until the submittal requirements are satisfied and found acceptable to the Engineer. Changes or deviations from the approved submittals must be resubmitted for approval. No adjustments in contract time will be allowed due to incomplete submittals.

Pre-Construction Meeting - A pre-construction meeting will be scheduled by the Engineer and held prior to the start of wall construction. The Engineer, prime Contractor, soil nail specialty Contractor and geotechnical instrumentation specialist (if applicable) shall attend the meeting. The excavation Contractor, shotcreting Contractor and survey Contractor, if different than the prime or soil nail specialty contractor, shall also attend. Attendance is mandatory. The pre-construction meeting will be conducted to clarify the construction requirements for the work, to coordinate the construction schedule and activities, and to identify contractual relationships and delineation of responsibilities amongst the prime Contractor and the various Subcontractors, particularly those pertaining to wall excavation, nail installation and testing, excavation and wall alignment survey control, and shotcrete and CIP facing construction. Soil nail wall construction requires excavation in staged lifts and excavation in the vicinity of the wall face requires special care and effort compared to general earthwork excavation. The Contractor shall take this into account during bidding and shall consult the Wall Excavation and Measurement/Payment Sections of this Specification for details.

MATERIALS

Furnish materials new and without defects. Remove defective materials from the job site at no additional cost. Materials for soil nail structures shall consist of the following:

Screw Anchors and Bolts - The screw anchors shall have a minimum ultimate tensile capacity of 70,000 lbs., and a minimum working torque capacity of 5500 foot-pounds, as manufactured by Hubbell Power Systems, Inc. (Centralia, Missouri). The anchors shall have 8-inch diameter helices at 29-inch nominal spacing along their length. Connecting bolts for the screw anchors shall have a minimum ultimate double shear strength of 70,000 lbs. The manufacturer shall have in effect industry-recognized written quality control for all materials and manufacturing processes. All welding shall be done by welders certified under section 4 of AWS code D1.1.

Cement: AASHTO M85/ASTM C150, Type I, II, III or V.

Fine Aggregate: AASHTO M6/ASTM C33.

Film Protection: Polyethylene film per AASHTO M171.

Drainage Material: Horizontal Drains - Provide as required and shown on the plans, slotted and unslotted PVC pipe conforming to AASHTO M-279. The contractor shall make provisions to assure that the hole does not collapse prior to the insertion of the slotted drain. Only the front 12 inches (30cm) of drain pipe shall be unslotted.

Vertical Wall Drains - Provide as required and shown on the plans, prefabricated, fully wrapped geocomposite drains. The core, not less than 0.25 or more than 0.50 inches (0.6 to 1.2 cm) thick, shall be either a preformed grid or embossed plastic or a system of plastic pillars and interconnections forming a semi-rigid mat. The core material, when covered with filter fabric, shall be capable of maintaining a drainage void for the entire height of permeable liner. Preformed drains shall be no wider than 12 inches (30 cm) unless special methods are used to ensure adherence of the shotcrete to the fabrics and to preclude the fabrics from sagging under the weight of the shotcrete. They shall be suitably outletted or connected to a longitudinal drain at the bottom of the structure. When splicing of drains is required, full flow through the splice shall be maintained, and splices shall be suitably protected from damage and contamination during subsequent shotcreting. The shotcrete shall be of full thickness over the drain.

Materials Handling And Storage - Store cement to prevent moisture degradation and partial hydration. Do not use cement that has become caked or lumpy. Store aggregates so that segregation and inclusion of foreign materials are prevented. Do not use the bottom 6 inches of aggregate piles in contact with the ground.

Store steel reinforcement on supports to keep the steel from contacting the ground. Do not ground welding leads to screw anchors.

CONSTRUCTION REQUIREMENTS

Site Drainage Control - Provide positive control and discharge of all surface water that will affect construction of the soil nail retaining wall. Maintain all pipes or conduits used to control surface water during construction. Repair damage caused by surface water at no additional cost. Upon substantial completion of the wall, remove surface water control pipes or conduits from the site. Alternatively, with the approval of the Engineer, pipes or conduits that are left in place may be fully grouted and abandoned or left in a way that protects the structure and all adjacent facilities from migration of fines through the pipe or conduit and potential ground loss.

The regional groundwater table is anticipated to be below the level of the wall excavation based on the results of the geotechnical site investigation. Localized areas of perched water or seepage may be encountered during excavation at the interface of geologic units or from localized groundwater seepage areas.

Immediately contact the Engineer if unanticipated subsurface drainage structures are discovered during excavation. Suspend work in these areas until remedial measures meeting the Engineer's approval are implemented. Capture surface water runoff flows and flows from existing subsurface drainage structures independently of the wall drainage network and convey them to an outfall structure or storm sewer, as approved by the Engineer. Cost of remedial measures required to capture and dispose of water resulting from encountering unanticipated subsurface drainage structures will be paid for as Extra Work.

Excavation - Coordinate the work and the excavation so the SOIL SCREW® Retention Wall System is properly constructed. Perform the wall construction and excavation sequence in accordance with the Plans and approved submittals. No excavation steeper than those specified herein or shown on the Plans will be made above or below the soil nail wall without written approval of the Engineer.

Excavation and Wall Alignment Survey Control - Unless specified otherwise, the Engineer will provide survey reference and control points at or offset along the top of wall alignment at approximate 30 foot intervals prior to starting wall excavation. The Contractor will then be responsible for providing the necessary survey and alignment control during excavation of each lift, locating and installing each nail within the allowable tolerances, and for performing the wall excavation and nail installation in a manner which will allow for constructing the shotcrete construction facing to the specified minimum thickness and such that the finish CIP structural facing can be constructed to the specified minimum thickness and to the line and grade indicated in the Plans. Where the as-built location of the front face of the shotcrete exceeds the allowable tolerance from the wall control line shown on the Plans, the Contractor will be responsible for determining and bearing the cost of remedial measures necessary to provide proper attachment of nail head bearing plate connections and satisfactory placement of the final facing, as called for on the Plans.

General Roadway Excavation - Complete clearing, grubbing, grading and excavation above and behind the wall before commencing wall excavation. Do not overexcavate the original ground behind the wall or at the ends of the wall, beyond the limits shown on the Plans. Do not perform general roadway excavation that will affect the soil nail wall until wall construction starts. Roadway excavation shall be coordinated with the soil nailing work, and the excavation shall proceed from the top down in a horizontal staged excavation lift sequence with the ground level for each lift excavated no more than mid-height between adjacent nail rows, as illustrated on the Plans. Do not excavate the full wall height to the final wall alignment as shown on the Plans but maintain a working bench of native material to serve as a platform for the drilling equipment. The bench shall be wide enough to provide a safe working area for the drill equipment and workers.

Perform any rock blasting within 200 feet of the soil nail wall using controlled blasting techniques designed by a qualified blasting consultant or a Professional Engineer registered in the state where the blasting is taking place. Blasting shall not damage completed soil nail work or disrupt the remaining ground to be soil nailed or shotcreted. Repair damaged areas at no additional cost.

Soil Nail Wall Structure Excavation - Structure excavation in the vicinity of the wall face will require special care and effort compared to general earthwork excavation. The excavation Contractor should take this into account during bidding. Due to the close coordination required between the soil nail Contractor and the excavation Contractor, the excavation Contractor shall perform the structure excavation for the soil nail wall under the direction of the soil nail specialty Contractor. The structure excavation pay limits are shown on the Plans.

Excavate to the final wall face using procedures that: (1) prevent over-excavation; (2) prevent ground loss, swelling, air slaking, or loosening; (3) prevent loss of support for completed portions of the wall; (4) prevent loss of soil moisture at the face; and (5) prevent ground freezing. Costs associated with additional thickness of shotcrete or concrete or other remedial measures required due to irregularities in the cut face, excavation overbreak or inadvertent over-excavation, shall be borne by the Contractor.

The exposed unsupported final excavation face cut height shall not exceed the vertical nail spacing plus the required reinforcing lap or the short-term stand-up height of the ground, whichever is less. Complete excavation to the final wall excavation line and application of the shotcrete in the same work shift unless otherwise approved by the Engineer. Application of the shotcrete may be delayed up to 24 hours if the Contractor can show that the delay will not adversely affect the excavation face stability. A polyethylene film over the face of the excavation may reduce degradation of the cut face caused by changes in moisture. Damage to existing structures or structures included in the Work shall be repaired and paid by the Contractor where approval is granted for the extended face exposure period.

At the Contractor's option, during each excavation lift, nails may be installed through a temporary stabilizing berm, as illustrated on the Plans. Purpose of the stabilizing berm is to prevent or minimize instability or sloughing of the final excavation face due to ground conditions and/or drilling action. The stabilizing berm geometry illustrated on the plans shows the top of berm extending horizontally out from the bottom front face of the overlying shotcrete a distance of 1 foot and cut down from that point to the base grade for that excavation lift at a slope not steeper than 1H:1V. The Contractor may use a different berm geometry than illustrated on the Plans, upon satisfactory demonstration that the different geometry provides satisfactory performance. Following the installation of nails in that lift, excavate the temporary stabilizing berm to the final wall face excavation line and clean the final excavation face of all loose materials, mud, and

other foreign matter which could prevent or reduce shotcrete bond. Ensure that installed nails and corrosion protection are not damaged during excavation of the stabilizing berm. Repair or replace nails damaged or disturbed during excavation of the stabilizing berm, to the Engineer's satisfaction, at no additional cost. Alternative excavation and soil nail installation methods that meet these objectives may be submitted to the Engineer for review in accordance with the Submittals section.

Excavation to the next level shall not proceed until nail installation, reinforced shotcrete placement, attachment of bearing plates and nuts and nail testing has been completed and accepted in the current lift. Shotcrete shall have cured for at least 72 hours or attained at least its specified 3-day compressive strength before excavating the next underlying lift. Excavating the next lift in less than 72 hours will only be allowed if the Contractor submits compressive strength test results, for tests performed by a qualified independent testing lab, verifying that the shotcrete mix being used will provide the specified 3-day compressive strengths in the lesser time.

Notify the Engineer immediately if raveling or local instability of the final wall face excavation occurs. Unstable areas shall be temporarily stabilized by means of buttressing the exposed face with an earth berm or other methods. Suspend work in unstable areas until remedial measures are developed.

Wall Discontinuities - Where the Contractor's excavation and installation methods result in a discontinuous wall along any nail row, the ends of the constructed wall section shall extend beyond the ends of the next lower excavation lift by at least 10 feet. Slopes at these discontinuities shall be constructed to prevent sloughing or failure of the temporary slopes. If sections of the wall are to be constructed at different times, prevent sloughing or failure of the temporary slopes at the end of each wall section.

Excavation Face Protrusions, Voids or Obstructions - Remove all or portions of cobbles, boulders, rubble or other subsurface obstructions encountered at the wall final excavation face which will protrude into the design shotcrete facing. Determine method of removal of face protrusions, including method to secure remnant pieces left behind the excavation face and for promptly backfilling voids resulting from removal of protrusions extending behind the excavation face. Notify the Engineer of the proposed method(s) for removal of face protrusions at least 24 hours prior to beginning removal. Voids, overbreak or over-excavation beyond the plan wall excavation line resulting from the removal of face protrusions or excavation operations shall be backfilled with shotcrete or concrete, as approved by the Engineer. Removal of face protrusions and backfilling of voids or over-excavation is considered incidental to the work. Cost due to removal of unanticipated man-made obstructions will be paid as Extra Work.

Nail Installation - Determine installation method necessary to achieve the nail pullout resistance(s) specified herein or on the Plans, in accordance with the nail testing acceptance criteria in the Nail Testing Section.

No installation of production nails will be permitted in any soil unit until successful pre-production verification testing of nails is completed in that unit and approved by the Engineer. Install verification test nails using the same equipment, methods, nail inclination and nail type as planned for the production nails. Perform pre-production verification tests in accordance with the Verification Testing Section prior to starting wall excavation and prior to installation of production nails in the specific lift in which the designated verification test nails are located. The number and location of the verification tests will be as indicated on the Plans or specified herein. Verification test nails may be installed through either the existing slope face prior to start of wall excavation, drill platform work bench, stabilization berm or into slot cuts made for the particular lift in which the verification test nails are located. Slot cuts will only be large enough to adequately accommodate the drill and test nail reaction setup. Subject to the Engineer's approval, verification test nails may also be installed at angle orientations other than perpendicular to the wall face or at different locations than specified, as long as the Contractor can demonstrate that the test nails will be installed into ground which is representative of the ground at the verification test nail locations designated on the Plans or herein. Install the production soil nails before the application of the reinforced shotcrete facing. At the Contractor's request and subject to the Engineer's written approval, the shotcrete facing may be placed before installing the nails. Provide a blockout through the shotcrete facing at drillhole locations using PVC pipe or other suitable material, to prevent damage to the facing during drilling. As part of the required construction submittals, provide the Engineer with acceptable structural design calculations demonstrating that the facing structural capacity will not be reduced and that the bearing plates are adequate to span the nail drillhole blockout through the construction facing. If this requires larger size bearing plates and/or additional reinforcement beyond that detailed on the Plans, the extra cost will be incidental.

Where necessary for stability of the excavation face, the Contractor shall have the option of placing a sealing layer (flashcoat) of unreinforced shotcrete or steel fiber reinforced shotcrete or of installation of nails through a temporary

stabilizing berm of native soil to protect and stabilize the face of the excavation per Section 3.2.3 Wall Structure Excavation. Cost shall be incidental to the Work.

During installation of nails, the torque required to install the nail shall be recorded.

The Engineer may add, eliminate, or relocate nails to accommodate actual field conditions. Cost adjustments associated with these modifications shall be made in accordance with the General Provisions of the Contract. The cost of any redesign, additional material, or installation modifications resulting from actions of the Contractor shall be borne by the Contractor.

Installation - The installation of the soil nails shall be made at the locations, orientations, and lengths shown on the Plans or as directed by the Engineer. Select installation equipment and methods suitable for the ground conditions described in the geotechnical report and shown in the boring logs. Select anchors required to develop the specified pullout resistance. It is the Contractor's responsibility to determine the final anchor configuration required to provide the specified pullout resistance. Where hard drilling conditions such as rock, cobbles, boulders, or obstructions are described elsewhere in the contract documents or project Geotechnical Report, other suitable drilling equipment and anchors capable of drilling through such materials, will be used.

Nail Installation Tolerances - Nails shall not extend beyond the right-of-way or easement limits shown on the Plans. Nail location and orientation tolerances are:

Nail head location, deviation from plan design location; 6 inches any direction.

Nail inclination, deviation from plan; + or - 3 degrees.

Location tolerances are applicable to only one nail and not accumulative over large wall areas.

Soil nails which do not satisfy the specified tolerances due to the Contractor's installation methods, will be replaced at no additional cost. Nails which encounter unanticipated obstructions during drilling shall be relocated, as approved by the Engineer. Cost of drilling new nails abandoned due to unanticipated obstructions will be paid as Extra Work.

Nail Testing - Perform both verification and proof testing of designated test nails. Perform pre-production verification tests on sacrificial test nails at locations shown on the Plans or listed herein. Perform proof tests on production nails at locations selected by the Engineer. Required nail test data shall be recorded by the Engineer. Do not perform nail testing until the shotcrete facing has cured for at least 72 hours and attained at least its specified 3-day compressive strength. Testing in less than 72 hours will only be allowed if the Contractor submits compressive strength test results for tests performed by a qualified independent test lab verifying that the shotcrete mix being used will provide the specified 3-day compressive strength in the lesser time. Alternatively, soil nails may be tested immediately after installation without a shotcrete facing, as long as precautions to maintain face stability are made (i.e., temporary lagging, etc.).

Proof Test Nail Unbonded Length - Provide lengths of smooth extensions without helices for each test nail. Isolate the test nail bar from the shotcrete facing and/or the reaction frame used during testing. Isolation of a test nail through the shotcrete facing shall not affect the location of the reinforcing steel under the bearing plate. Submit the proposed test nail isolation methods, and the location and length of smooth extensions and test nails prior to testing to the Engineer for review and approval in accordance with the Submittals Section.

Testing Equipment - Testing equipment shall include dial gauges, dial gauge support, jack and pressure gauge, electronic load cell, and a reaction frame. The load cell is required only for the creep test portion of the verification test. Provide description of test setup and jack, pressure gauge and load cell calibration curves in accordance with Submittals Section.

Design the testing reaction frame to be sufficiently rigid and of adequate dimensions such that excessive deformation of the testing equipment does not occur. If the reaction frame will bear directly on the shotcrete facing, design it to prevent cracking of the shotcrete. Independently support and center the jack over the nail bar so that the nail does not carry the weight of the testing equipment. Align the jack, bearing plates, and reaction frame with the nail such that unloading and repositioning of the equipment will not be required during the test.

Apply and measure the test load with a hydraulic jack and pressure gauge. The pressure gauge shall be graduated in 50 psi increments or less. The jack and pressure gauge shall have a pressure range not exceeding twice the anticipated maximum test pressure. Jack ram travel shall be sufficient to allow the test to be done without resetting the equipment. Monitor the nail load during verification tests with both the pressure gauge and the load cell. Use the load cell to maintain constant load hold during the creep test load hold increment of the verification test.

Measure the nail head movement with a dial gauge capable of measuring to .001 inch. The dial gauge shall have a travel sufficient to allow the test to be done without having to reset the gauge. Visually align the gauge to be parallel with the axis of the nail and support the gauge independently from the jack, wall, or reaction frame. Use two dial gauges when the test setup requires reaction against a soil cut face. One dial gauge should measure movement of the reaction relative to the soil face, and one relative to the reaction frame.

Pre-production Verification Testing of Sacrificial Test Nails - Pre-production verification testing shall be performed prior to installation of production nails to verify the Contractor's installation methods and nail pullout resistance. Perform pre-production verification tests at the locations and elevations shown on the Plans or herein, and per Nail Installation Section 3.3, unless otherwise approved by the Engineer. Perform a minimum of two verification tests in each different soil unit and for each different drilling method proposed to be used, at each wall location. Verification test nails will be sacrificial and not incorporated as production nails. Black steel anchors can be used for the sacrificial verification test nails.

Develop and submit the details of the verification testing arrangement including the method of distributing test load pressures to the excavation surface (reaction frame), and reaction frame dimensioning to the Engineer for approval in accordance with Submittals Section. Construct verification test nails using the same equipment, installation methods, nail inclination, and drilling equipment as planned for the production nails. Changes in the installation method may require additional verification testing as determined by the Engineer and shall be provided at no additional cost. Payment for additional verification tests required due to differing site conditions, if determined by the Engineer, shall be per the contract unit price.

Test nails shall have lengths of smooth extensions in addition to the test nail with helices. The length of the smooth extensions within the test nail shall be at least 3 feet. The number of helices on the test nail shall be determined based on the production nail strength and helix configuration such that the allowable soil nail structural load is not exceeded during testing, but shall not be less than 3. The allowable soil nail structural load during testing shall not be greater than 80 percent of the rated minimum ultimate strength of the nail. The Contractor shall provide larger verification test soil nails, if required, to safely accommodate the 3-helix minimum and testing to 1.5 times the allowable pullout resistance per helix, at no additional cost.

The Design Test Load (DTL) shall be determined by one of the following two methods. The first method is based on ultimate pullout capacity and is explained below. The second method is based on the nail with the highest load as determined by the internal and compound stability analysis.

$$DTL = 1/2P \leq 0.49 \text{ allowable soil nail structural load (Kips)}$$

$$P = \text{Ultimate Pullout Capacity, specified herein or on the Plans (Kips)}$$

$$MTL = \text{Maximum Test Load} = 1.5 \times DTL \text{ (Kips)}$$

where:

$$P = \sum_{i=1}^n A_i q_i N_{qi} \leq 55 \text{ Kips}$$

P = ultimate pullout capacity

A_i = area of helix i

q_i = effective overburden pressure at helix i

q_i = γ' z_i

γ' = effective unit weight of the soil

z_i = depth from the ground surface to helix i

N_{qi} = the bearing capacity factor at helix i

If the Design Test Load (DTL) is based on the internal and compound stability analysis, DTL should be equal to the highest nail load determined by said analysis, but should never exceed 0.49 times the allowable soil nail structural load.

Verification test nails shall be incrementally loaded to a maximum test load of 150 percent of the Design Test Load in accordance with the following loading schedule. The soil nail movements shall be recorded at each load increment.

VERIFICATION TEST LOADING SCHEDULE	
LOAD	HOLD TIME
AL (0.20 DTL max.)	1 minute
0.25 DTL	10 minutes
0.50 DTL	10 minutes
0.75 DTL	10 minutes
1.00 DTL	10 minutes
1.25 DTL	10 minutes
1.50 DTL (Creep Test)	60 minutes

The alignment load (AL) should be the minimum load required to align the testing apparatus and should not exceed 20 percent of the Design Test Load (DTL). The alignment load (AL) should be released to 5 percent, and then dial gauges should be set to “zero.”

Each load increment shall be held for at least 10 minutes. The verification test nail shall be monitored for creep at the 1.50 DTL load increment. Nail movements during the creep portion of the test shall be measured and recorded at 1 minute, 2, 3, 5, 6, 10, 20, 30, 50, and 60 minutes. The load during the creep test shall be maintained within 2 percent of the intended load by use of the load cell.

Proof Testing of Production Nails - Perform proof testing on 3 percent (1 in 33) of the production nails in each nail row or minimum of 1 per row. The locations shall be designated by the Engineer. A verification test nail successfully completed during production work shall be considered equivalent to a proof test nail and shall be accounted for in determining the number of proof tests required in that particular row.

Production proof test nails shall have lengths of smooth extensions in addition to the soil nail with helices. The temporary smooth extension length of the test nail shall be at least 3 feet. The number of helices shall be determined based on the allowable design load not being exceeded during testing, but shall not be less than 3. The allowable soil nail structural load during testing shall not be greater than 80 percent of the rated minimum ultimate strength for the soil nail. The minimum length of proof tested production nails is 10 ft.

The Design Test Load (DTL) shall be determined by one of the following two methods. The first method is based on ultimate pullout capacity and is explained below. The second method is based on the nail with the highest load as determined by the internal and compound stability analysis.

$$DTL = 1/2P \leq 0.49 \text{ allowable soil nail structural load (Kips)}$$

$$P = \text{Ultimate Pullout Capacity, specified herein or on the Plans (Kips)}$$

$$MTL = \text{Maximum Test Load} = 1.5 \times DTL \text{ (Kips)}$$

where:

$$P = \sum_{i=1}^n A_i q_i N_{qi} \leq 55 \text{ Kips}$$

P = ultimate pullout capacity

A_i = area of helix i

q_i = effective overburden pressure at helix i

$$q_i = \gamma' z_i$$

γ' = effective unit weight of the soil

z_i = depth from the ground surface to helix i

N_{qi} = the bearing capacity factor at helix i

If the Design Test Load (DTL) is based on the internal and compound stability analysis, DTL should be equal to the highest nail load determined by said analysis, but should never exceed 0.49 times the allowable soil nail structural load.

Proof tests shall be performed by incrementally loading the proof test nail to a maximum test load of 150 percent of the Design Test Load (DTL). The nail movement at each load shall be measured and recorded by the Engineer in the same manner as for verification tests. The test load shall be monitored by a jack pressure gauge with a sensitivity and range meeting the requirements of pressure gauges used for verification test nails. At load increments other than maximum test load, the load shall be held long enough to obtain a stable reading. Incremental loading for proof tests shall be in accordance with the following loading schedule. The nail movements shall be recorded at each load increment.

PROOF TEST LOADING SCHEDULE	
LOAD	HOLD TIME
AL (0.20 DTL max.)	Until Stable
0.25 DTL	Until Stable
0.50 DTL	Until Stable
0.75 DTL	Until Stable
1.00 DTL	Until Stable
1.25 DTL	Until Stable
1.50 DTL (Max. Test Load)	See Below

The alignment load (AL) should be the minimum load required to align the testing apparatus and should not exceed 5 percent of the Design Test Load (DTL). Dial gauges should be set to “zero” after the alignment load has been applied.

All load increments shall be maintained within 5 percent of the intended load. Depending on performance, either 10 minute or 60 minute creep tests shall be performed at the maximum test load (1.5 DTL). The creep period shall start as soon as the maximum test load is applied, and the nail movement shall be measured and recorded at 1 minute, 2, 3, 5, 6, and 10 minutes. Where the nail movement between 1 minute and 10 minutes exceeds .08 inches, the maximum test load shall be maintained until the soil nail movement is less than .08 inches for any one log increment (i.e., 2 minutes and 20 minutes, etc.).

Test Nail Acceptance Criteria - A test nail shall be considered acceptable when the following criteria are met:

1. For verification tests, a total creep movement of less than .08 inches per log cycle of time between the 6 and 60 minute readings is measured during creep testing, and the creep rate is linear or decreasing throughout the creep test load hold period.
2. For proof tests, a total creep movement of less than .08 inches is measured between the 1 and 10 minute readings, or a total creep movement of less than .08 inches is measured between the subsequent log cycles, and the creep rate is linear or decreasing throughout the creep test load hold period.
3. For proof and verification tests, a pullout failure does not occur at the maximum test load. Pullout failure is defined as the load at which attempts to further increase the test load simply result in continued pullout movement of the test nail. The pullout failure load shall be recorded as part of the test data. the jacking frame and appurtenant bracing.

Successful proof tested nails meeting the above test acceptance criteria may be incorporated as production nails, provided that the number of helices on the test nail is equal to or greater than the scheduled production nail length. If the production proof test nail does not meet this criteria, it shall become sacrificial and shall be replaced with an additional production nail installed at no additional cost.

Test Nail Rejection - If a test nail does not satisfy the acceptance criterion, the Contractor shall determine the cause.

Verification Test Nails - The Engineer will evaluate the results of each verification test. Installation methods which do not satisfy the nail testing requirements shall be rejected. The Contractor shall propose alternative methods and install replacement verification test nails. Replacement test nails shall be installed and tested at no additional cost.

Proof Test Nails - The Engineer may require the Contractor to replace some or all of the installed production nails between a failed proof test nail and the adjacent passing proof test nail. Alternatively, the Engineer may require the installation and testing of additional proof test nails to verify that adjacent previously installed production nails have sufficient load

carrying capacity. Contractor modifications may include, but are not limited to; the installation of additional proof test nails, modifying the installation method; reducing the production nail spacing from that shown on the Plans and installing more production nails at a reduced capacity; or installing longer production nails if sufficient right-of-way is available, and the pullout capacity behind the failure surface controls the allowable nail design capacity. The nails may not be lengthened beyond the temporary construction easements or the permanent right-of-way shown on the Plans. Installation and testing of additional proof test nails or installation of additional or modified nails as a result of proof test nail failure(s) will be at no additional cost.

Nail Installation Records - Records documenting the soil nail wall construction will be maintained by the Engineer, unless specified otherwise. The Contractor shall provide the Engineer with as-built drawings showing as-built nail locations and as-built shotcrete facing line and grade within 5 days after completion of the shotcrete facing, and as-built CIP facing line and grade within 5 days after completion of the CIP facing.

METHOD OF MEASUREMENT

The unit of measurement for production soil nails will be per lineal foot. The length to be paid will be the length measured along the bar centerline from the back face of shotcrete to the bottom tip end of nail bar as shown on the Plans. No separate measurement will be made for proof test nails, which shall be considered incidental to production nail installation. Specified verification test nails will be measured on a unit basis for each verification test successfully completed. Failed verification test nails or additional verification test nails installed to verify alternative nail installation methods proposed by the Contractor will not be measured.

Structure Excavation for Soil Nail Wall will be measured as the theoretical plan volume in cubic meters within the structure excavation pay limits shown on the Plans. This will be the excavation volume within the zone measured from top to bottom of shotcrete wall facing and extending out 6 feet horizontally in front of the plan wall final excavation line. Additional excavation beyond the plan wall final excavation line resulting from irregularities in the cut face, excavation overbreak or inadvertent excavation, will not be measured.

General roadway excavation will not be a separate wall pay item, but will be measured and paid as part of the general roadway excavation including haul pay item.

The final pay quantities will be the design quantity increased or decreased by any changes authorized by the Engineer.

BASIS OF PAYMENT

The accepted quantities of soil nails and soil nail wall structure excavation will be paid for at the contract unit prices. Payment will be full compensation for all labor, equipment, materials, material tests, field tests and incidentals necessary to acceptably fabricate and construct the soil nails and perform the structure excavation, including the excavation and wall alignment survey control, for the soil nail wall(s) in accordance with all requirements of the contract. Payment will be made for each of the following bid items included in the bid form:

Pay Item	Measurement Unit
Permanent Soil Nails	Lineal Feet
Verification Test Nails	Each
Structure Excavation - Soil Nail Wall	Cubic Yards

END OF SECTION

APPENDIX B2: GUIDE SPECIFICATION FOR SOIL SCREW® RETENTION WALL SYSTEMS (DESIGN-BUILD SOLICITATION)

(Commentary: This guide specification is set up for a post-bid design solicitation to solicit Soil Screw Retention™ Wall System designs where the Owner has selected a soil nail wall as the preferred wall type for the given wall location(s). It can be modified as appropriate to also serve as a pre-bid design solicitation and/or for a solicitation where alternate wall types are allowed by the Owner, with the Contractor allowed to select and submit a design for the wall type which the Contractor feels is most cost-effective.)

DESCRIPTION

This work consists of designing and constructing permanent SOIL SCREW® Retention Wall System(s) at the locations shown on the “Layout Drawings.” The Contractor shall furnish all labor, plans, drawings, design calculations, or other materials and equipment required to design and construct the wall(s) in accordance with this Specification and the _____ Standard Specifications. *(Commentary: If walls are temporary rather than permanent, revise above wording.)*

Where the imperative mood is used within this Specification for conciseness, “the Contractor shall” is implied.

Contractor’s Experience Requirements - The Contractor shall be experienced in the construction of permanent soil nail retaining walls and have successfully constructed at least 3 projects in the last 3 years involving construction of permanent soil nail retaining walls totaling at least 10,000 square feet of wall face area and at least 500 permanent soil nails. A brief description of each project with the Owner’s name and current phone number shall be included.

A Registered Professional Engineer employed by the soil nailing Contractor and having experience in the construction of at least 3 completed permanent soil nail retaining wall projects over the past 3 years, shall supervise the work. The Contractor shall not use consultants or manufacturer’s representatives to satisfy the supervising Engineer requirements of this section.

The soil nail wall shall be designed by a Registered Professional Engineer with experience in the design of at least 3 successfully completed permanent soil nail retaining wall projects over the past 3 years. The wall designer may be either an employee of the Contractor or a separate Consultant designer meeting the stated experience requirements.

At least 45 calendar days before the planned start of wall excavation, the Contractor shall submit the experience qualifications and details for the referenced design and construction projects, including a brief project description with the owner’s name and current phone number. Upon receipt of the experience qualifications submittal, the Engineer will have 15 calendar days to approve or reject the proposed soil nailing Contractor and Designer.

Pre-Approval List

The following soil nailing design-build specialty Contractors are pre-approved:

1. Contractor Name
Mailing Address
Contact Name
Phone Number
2. Contractor Name
Mailing Address
Contact Name
Phone Number
3. Contractor Name
Mailing Address
Contact Name
Phone Number

SPECIFICATIONS





Available Information - Available information developed by the Owner, or by the Owner’s duly-authorized representative include the following items:

1. “Layout Drawings” prepared by _____, dated _____.The “Layout Drawings” include the approved preliminary plans, profile and typical cross sections for the proposed SOIL SCREW® Retention Wall System locations. (Commentary-Specifier: Refer to Chapter 8 of the FHWA “Manual for Design and Construction Monitoring of Soil Nail Walls,” Report No. FHWA-SA-96-069 for detailed guidance on conceptual plan information to provide on the Design-Build “Layout Drawings.”)
2. Geotechnical Report No. ____, titled _____, dated _____, included in the bid documents, contains the results of test pits, exploratory borings and other site investigation data obtained in the vicinity of the proposed wall locations.

Soil Nail Wall Design Requirements - Design the soil nail walls using the CHANCE SOIL SCREW® Design Manual Using the SOIL SCREW® Retention Wall System. The required partial safety factors, allowable strength factors and minimum global stability soil factors of safety shall be in accord with the manual, unless specified otherwise. Estimated soil design shear strength parameters, slope and external surcharge loads, type of wall facing and facing architectural requirements, soil nail corrosion protection requirements, known utility locations, easements, and rights-of-way will be as shown on the “Layout Drawings” or specified herein. Structural design of any individual wall elements not covered in the manual shall be by the service load or load factor design methods in conformance with Article 3.22 and other appropriate articles of the 15th Edition of the AASHTO Standard Specifications for Highway Bridges including current interim specifications. The seismic design acceleration coefficient is _____g.

Soil Nail Wall Design Submittals - At least 30 calendar days before the planned start of wall excavation, submit complete design calculations and working drawings to the Engineer for review and approval. Include all details, dimensions, quantities, ground profiles, and cross-sections necessary to construct the wall. Verify the limits of the wall and ground survey data before preparing drawings.

Design Calculations - Design calculations shall include, but not be limited to, the following items:

- (1) A written summary report which describes the overall soil nail wall design.
- (2) Applicable code requirements and design references.
- (3) Soil Nail wall critical design cross-section(s) geometry including soil strata and location, magnitude, and direction of design slope or external surcharge loads and piezometric levels.
- (4) Design criteria including soil shear strength (friction angle and cohesion), unit weights, and screw anchor pullout resistance.
- (5) Design calculation sheets with the project number, wall location, designation, date of preparation, initials of designer and checker, and page number at the top of each page. Provide an index page with the design calculations.
- (6) Design notes including an explanation of any symbols and computer programs used in the design.
- (7) Soil Nail wall final design cross-section(s) geometry including soil strata and location, magnitude, and direction of slope or external surcharge loads and piezometric levels with critical slip surface shown along with minimum calculated global stability soil factor of safety for SLD design, and required nail lengths and strengths for each nail row.
- (8) Structural design calculations for wall facing(s) and nail head/facing connections including consideration of facing flexural and punching shear strength, headed studs tensile strength, upper cantilever, minimum reinforcement ratio, cover and splice requirements.
- (9) Other design calculations.

SPECIFICATIONS



Working Drawings - Working drawings shall include, but not be limited to, the following items:

- (1) A plan view of the wall(s) identifying:
 - (a) A reference baseline and elevation datum.
 - (b) The offset from the construction centerline or baseline to the face of the wall at its base at all changes in horizontal alignment.
 - (c) Beginning and end of wall stations.
 - (d) Right-of-way and permanent or temporary construction easement limits, location of all known active and abandoned existing utilities, adjacent structures or other potential interference. The centerline of any drainage structure or drainage pipe behind, passing through, or passing under the wall.
 - (e) Limit of longest nails.
 - (f) Subsurface exploration locations shown on a plan view of the proposed wall alignment with appropriate reference baselines to fix the locations of the explorations relative to the wall.
- (2) An elevation view of the wall(s) identifying:
 - (a) The elevation at the top of the wall, at all horizontal and vertical break points, and at least every 30 feet along the wall.
 - (b) Elevations at the wall base and the top of leveling pads for casting CIP facing (if applicable).
 - (c) Beginning and end of wall stations.
 - (d) The distance along the face of the wall to all steps in the wall base.
 - (e) Nail locations and elevations; vertical and horizontal nail spacing; and the location of wall drainage elements and permanent facing expansion/contraction joints (if applicable) along the wall length.
 - (f) Existing and finish grade profiles both behind and in front of the wall.
- (3) Design parameters and applicable codes.
- (4) General notes for constructing the wall including construction sequencing or other special construction requirements.
- (5) Horizontal and vertical curve data affecting the wall and wall control points. Match lines or other details to relate wall stationing to centerline stationing.
- (6) A listing of the summary of quantities on the elevation drawing of each wall showing estimated square feet of wall face areas and other pay items.
- (7) Wall typical section including staged excavation lift elevations, wall and excavation face batter, nail spacing and inclination, nail bar sizes, and corrosion protection details.
- (8) A typical detail of production and test nails defining the nail length, inclination, and test nail configuration.
- (9) Details, dimensions, and schedules for all nails, reinforcing steel, wire mesh, bearing plates, headed studs, etc., and/or attachment devices for shotcrete, cast-in-place or prefabricated facings.
- (10) Dimensions and schedules of all reinforcing steel including reinforcing bar bending details.
- (11) Details and dimensions for wall appurtenances such as barriers, coping, drainage gutters, fences, etc.
- (12) Details for constructing walls around drainage facilities.
- (13) Details for terminating walls and adjacent slope construction.
- (14) Facing finishes, color and architectural treatment requirements (if applicable) for permanent wall facing elements.

The drawings and calculations shall be signed and sealed by the Contractor’s Professional Engineer and by the Consultant designer’s Professional Engineer (if applicable), previously approved by the Owner’s Engineer. If the soil nail Contractor uses a Consultant designer subcontractor to prepare the design, the soil nail Contractor shall still have overall contract responsibility for both the design and the construction.

Submit three sets of the wall drawings with the initial submission. One set will be returned with any indicated corrections. The Engineer will approve or reject the Contractor’s submittals within 15 calendar days after receipt of a complete submission. If revisions are necessary, make the necessary corrections and resubmit three revised sets. When the drawings are approved, furnish five sets and a Mylar sepia set of the drawings. The Contractor will not be allowed to begin wall construction or incorporate materials into the work until the submittal requirements are satisfied and found acceptable to the Engineer. Changes or deviations from the approved submittals must be resubmitted for approval. No adjustments in contract time will be allowed due to incomplete submittals.

Revise the drawings when plan dimensions are revised due to field conditions or for other reasons. Within 30 days after completion of the work, submit as-built drawings to the Engineer. Provide revised design calculations signed by the approved Registered Professional Engineer for all design changes made during the construction of the wall.

MATERIALS AND CONSTRUCTION REQUIREMENTS

Construct the wall according to the approved drawings and the appropriate Sections in the Standard Specifications as applicable. Materials and construction requirements will be as set forth in the Permanent Soil Nail and Wall Excavation and Temporary Shotcrete Facing and Wall Drainage Specifications. All portions of these Specifications will apply except for Measurement and Payment, which will be as set forth below.

(Commentary: This solicitation is written assuming the Owner Agency will still provide construction inspection of the design-build construction. If not the case, and more responsibility for construction inspection and testing is to be placed on the Contractor, then the referenced construction specifications should be modified accordingly.)

METHOD OF MEASUREMENT

The unit of measurement for soil nailed walls will be lump sum for each wall listed on the bid schedule. When plan dimension changes are authorized during construction to account for field conditions, the lump sum price of the wall will be adjusted by applying a calculated per square foot cost adjustment factor to the added or decreased wall front face area resulting from the change. The adjustment factor will be determined by dividing the lump sum price bid for each wall by its original shotcrete facing front face area shown on the original approved working drawings. If the actual quantity increases or decreases by more than ____ percent from the original plan quantity, as authorized by the Engineer, the contract price will be adjusted per subsection _____ of the Standard Specifications.

BASIS OF PAYMENT

Payment will be full compensation for all labor, equipment, materials, tests, and incidentals necessary to acceptably design and construct the SOIL SCREW® Retention Wall System, including the wall drainage network and the temporary shotcrete construction facing or permanent shotcrete facing (if applicable).

Pay Item	Measurement Unit
Soil Nail Retaining Wall No. 1	Lump Sum
Soil Nail Retaining Wall No. 2 Lump Sum	Lump Sum

If required, permanent CIP facings or CIP drainage gutters will be measured and paid for separately per Lump Sum in accordance with Section _____ of the Standard Specifications or CIP Facing special provision.

SPECIFICATIONS

GLOSSARY of TERMS

β	Angle of slope above the top of the wall measured from horizontal
β'	Net angle of broken back slope
δ	The wall friction angle assumed to be equal to zero
θ	Wall face batter measured from vertical
γ	Effective unit weight of soil
ϕ	Angle of internal friction; angle of shearing resistance
ϕ'	Effective angle of internal friction
σ	Normal stress
π	pi, which equals 3.1417
A_b	The cross-sectional area of the bolt at the end of the service life of the nail (considering corrosion)
A_c	The design cross-sectional area of the steel (defined as the original cross-sectional area minus corrosion losses anticipated during the design life of the wall)
A_i	Area of helix i
A_s	Area of vertical steel over the nails (negative moment) and at the midspan (positive moment)
b	Width of the beam (horizontal spacing between nails)
c	Cohesion of the soil
c'	Effective cohesion of the soil
C_F	Dimensionless factor to account for facing flexibility
c_i	Effective cohesion at helix i
d	Distance from the extreme face of the shotcrete to the centroid of the reinforcement
D'_c	Effective cone diameter at the center of the facing
e	Eccentricity of resultant vertical bearing force (ft)
f'_c	Compressive strength of the concrete
FS	Factor of safety
F_H	Horizontal component of inclined earth force on wall
F_y	The yield stress of the steel
F_v	Vertical component of inclined earth force on wall
F_v	Shear strength of the steel
F_1	Lateral earth force on wall
F_2	Lateral surcharge force on wall
GOLDNAIL	Computer program developed to determine the stability of soil nail walls

H	Height of reinforced soil mass at wall or the height of a tieback wall as used on Figure 1.2.5 re: "Tieback Wall"
h	Height of reinforced soil mass at ends of nails
h_c	Thickness of the shotcrete facing
K_a	Coefficient of active earth pressure
L	Horizontal length of soil nails
M_c	Cantilever moment that the wall must resist
N_c	Bearing capacity factor for helical anchor in clay
N_{qi}	Bearing capacity factor at helix i
P	Pullout capacity
q	Surcharge loading on retained soil
q_i	Effective overburden pressure at helix i
R	Resisting force
s'	Effective shear strength of the soil
S_H	Horizontal nail spacing
SNAIL	Computer programs to determine the stability of soil nail walls
STABL	Computer programs to determine the stability of soil nail walls
S_V	Vertical nail spacing
T	Tensile force provided by the screw anchor
V	Design shear strength
V_N	Punching shear strength of the facing system
W_1	Weight of reinforced soil block
W_2	Weight of slope above reinforced soil block
z_i	Depth from the ground surface to helix i



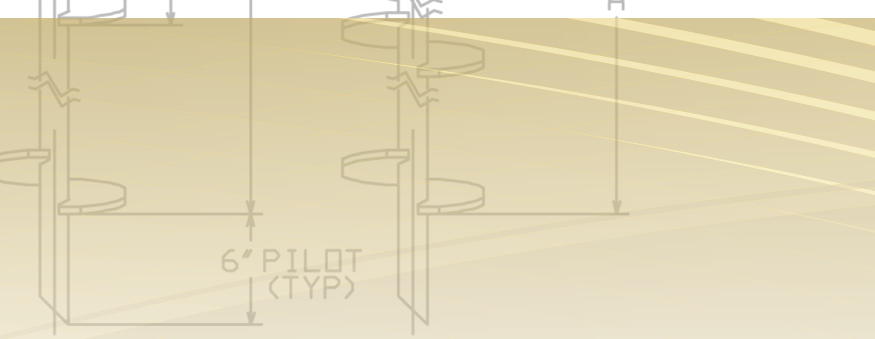
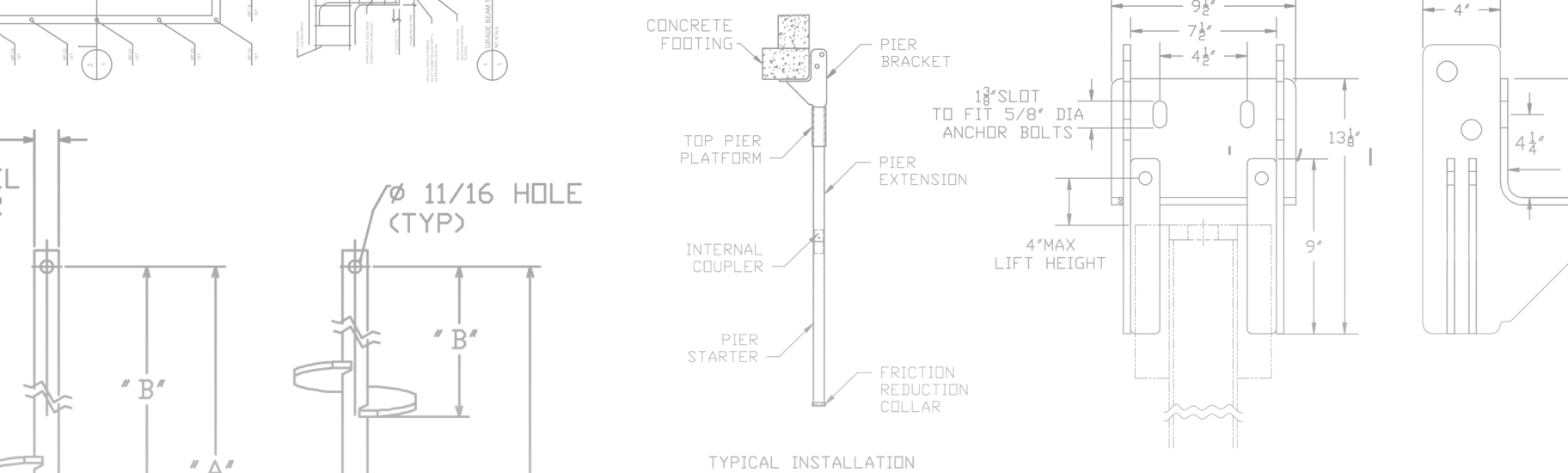

SINGLE HELIX LEAD SECTION *TRIPLE HELIX LEAD SECTION*

SOIL SCREW LEADS

<i>NO.</i>	<i>NO. OF HELIX</i>	<i>DIA. OF HELIX</i>	<i>"A"</i>	<i>"B"</i>	<i>FINISH</i>
	2	6"	58.0"	28.0"	GALV.
	2	8"	58.0"	28.0"	GALV.

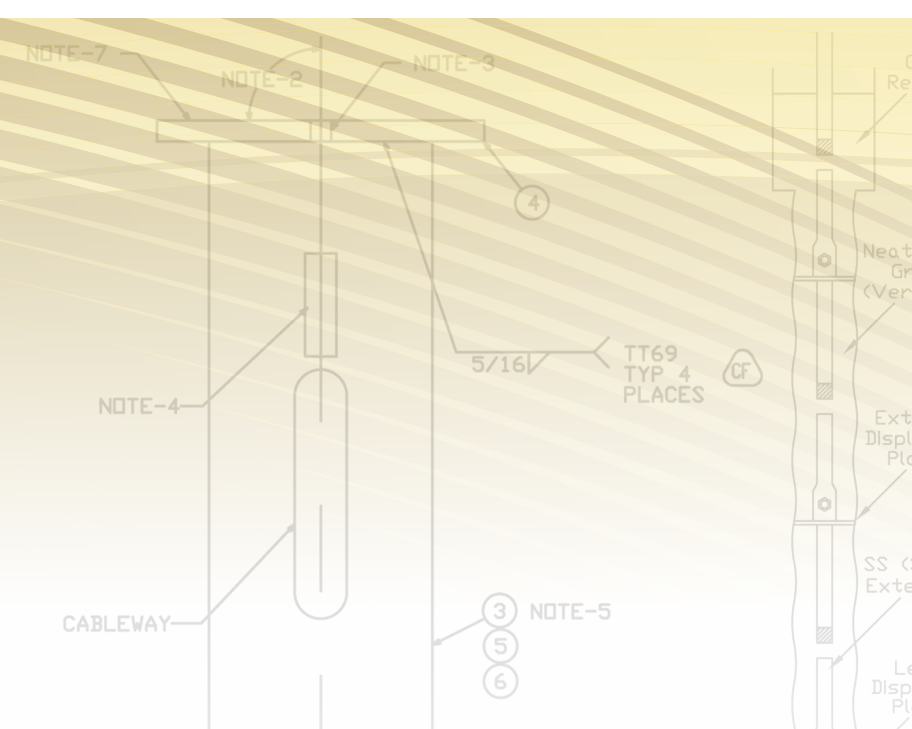

G	3	6"	77.0"	47.0"	NON GALV.
G	3	8"	77.0"	47.0"	NON GALV.



CHANCE Civil Construction | Hubbell Power Systems, Inc.
Centralia, Missouri 65240 | U.S.A.



© Copyright 2015 Hubbell Incorporated | Printed in the U.S.A.

Bulletin TD_04_088_E | Revision 06-12-15



**Because Hubbell has a policy of continuous product improvement,
we reserve the right to change design and specifications without notice.**